

# Foundations of functional MRI: physics and neurophysiology

Methods and Models in fMRI, 24.09.2019

Jakob Heinzle

[heinzle@biomed.ee.ethz.ch](mailto:heinzle@biomed.ee.ethz.ch)

Translational Neuromodeling Unit (TNU)  
Institute for Biomedical Engineering (IBT)  
University and ETH Zürich

Many thanks to  
K. E. Stephan for material



Translational Neuromodeling Unit



University of  
Zurich<sup>UZH</sup>

**ETH**

Eidgenössische Technische Hochschule Zürich  
Swiss Federal Institute of Technology Zurich

# A very simple experiment

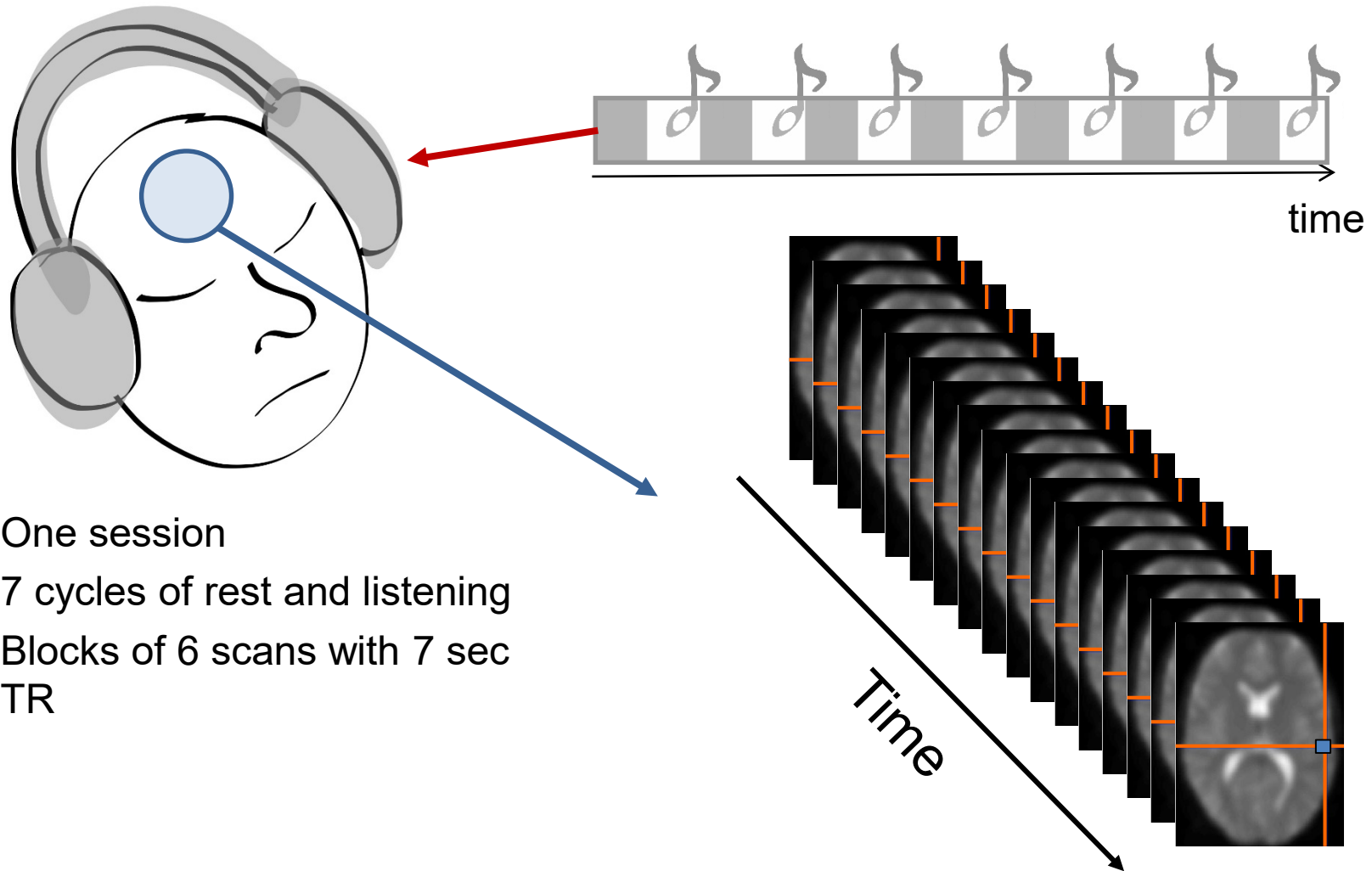

- One session
- 7 cycles of rest and listening
- Blocks of 6 scans with 7 sec TR

# How is brain data related to the input?

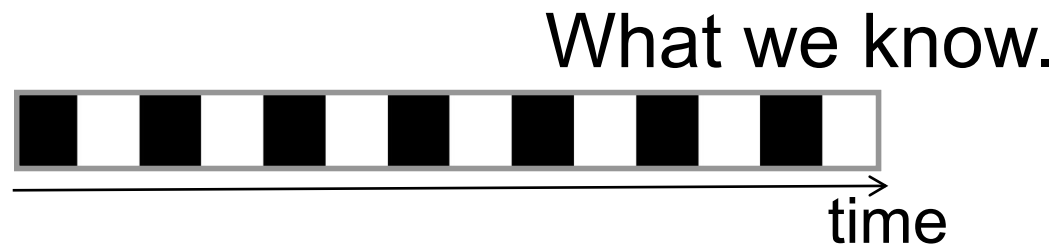
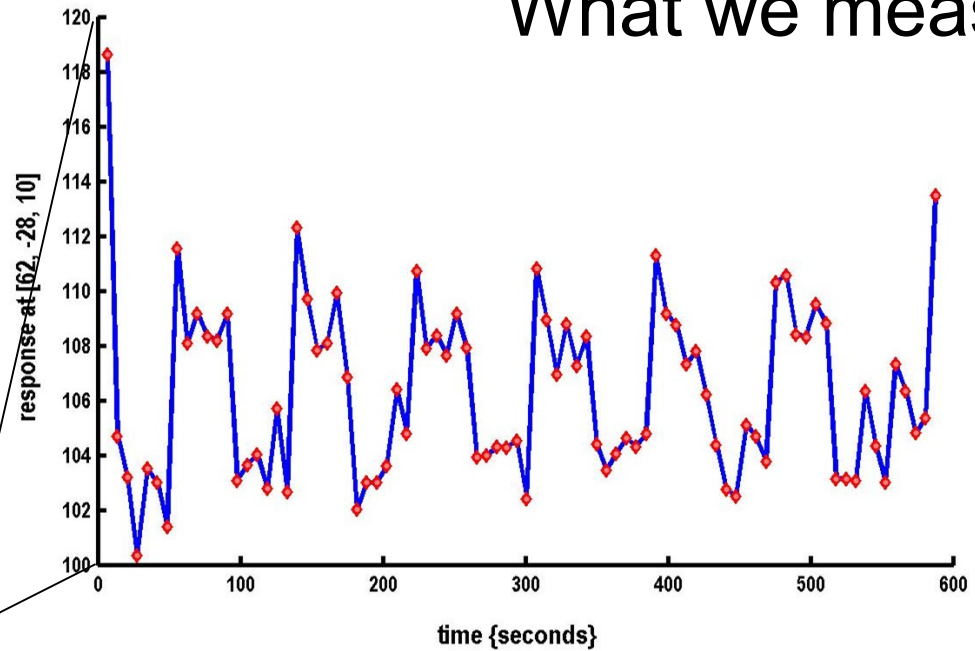
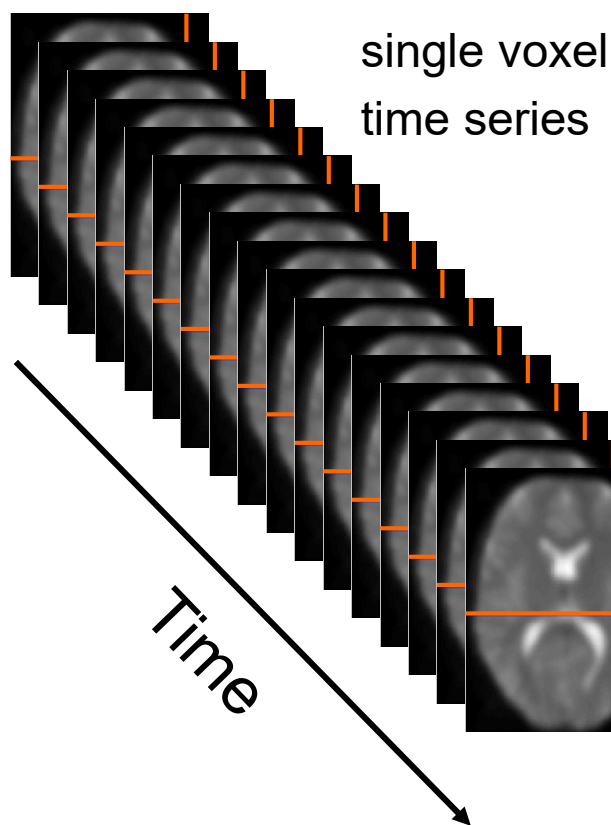

# Statistical maps

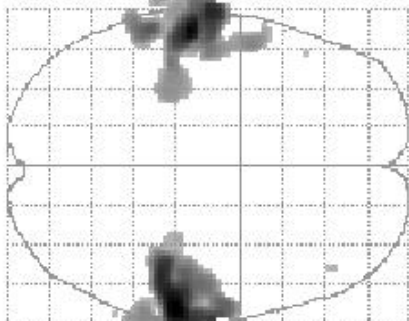
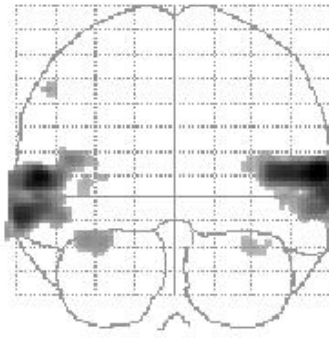
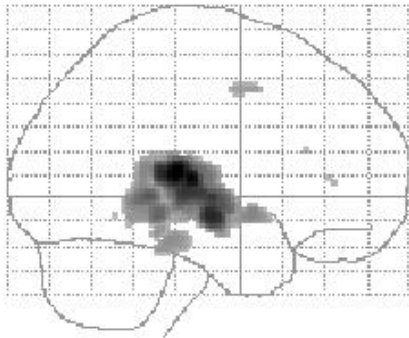

$SPM\{T_{73}\}$

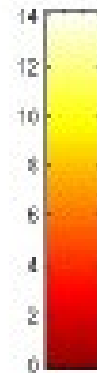
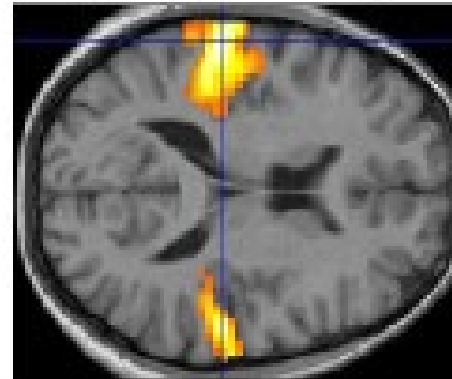
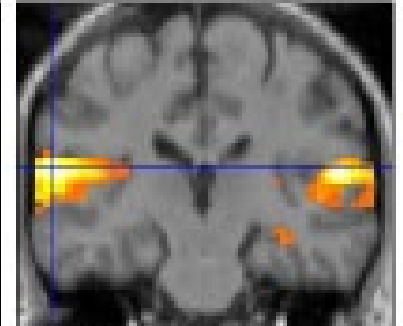
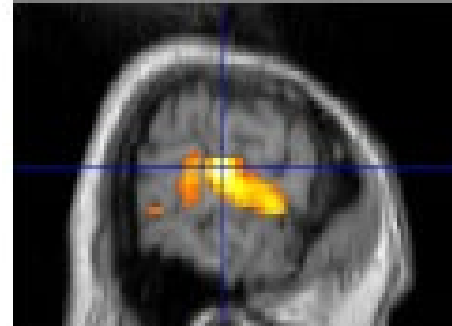

Glass brain

Sections

# Overview of SPM

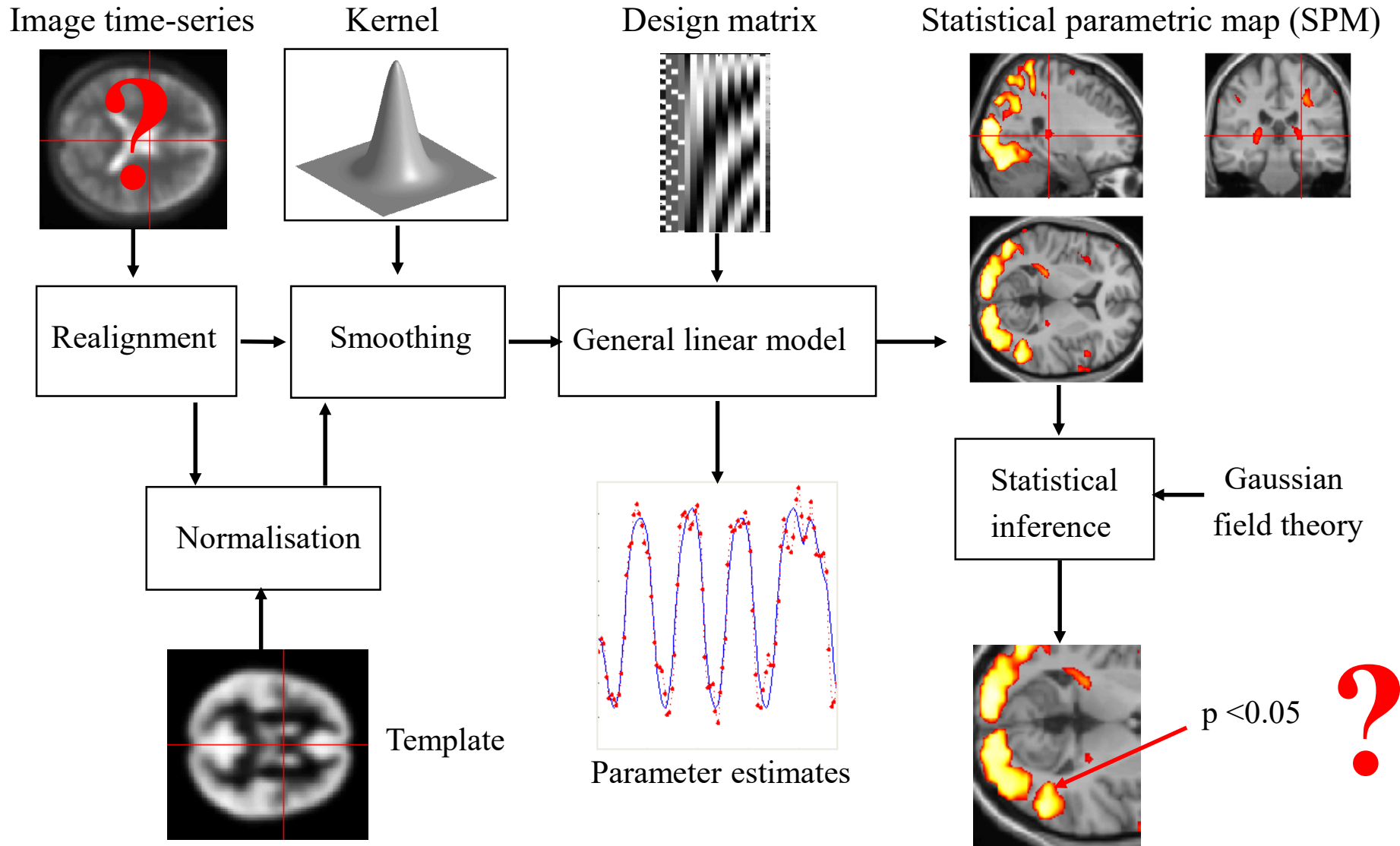

# Indirect relationship between cognitive processes, neural processing and fMRI

Cognitive processes (Sensory, motor, etc. )

Control and measure

Information processing in ensembles of neurons,  
e.g. synaptic processes and neural spiking

Try to infer something about

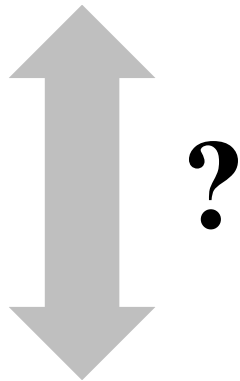

Measured MRI signal

Source, Huettel et al, 2004, fMRI (Book)

# Indirect relationship between cognitive processes, neural processing and fMRI

Cognitive processes (Sensory, motor, etc. )

Control and measure

Information processing in ensembles of neurons,  
e.g. synaptic processes and neural spiking

Try to infer something about

**3. How is the BOLD signal related to neural processing?**

Changes in blood flow, oxygen concentration,  
blood volume

**2. What do we measure with fMRI?**

Changes in MRI contrasts due to changes in  
relative hemoglobin concentrations

**1. What do we measure with MRI?**

Measured MRI signal

Source, Huettel et al, 2004, fMRI (Book)

# 1. What do we measure with MRI?

Cognitive processes (Sensory, motor, etc. )

Control and measure

Information processing in ensembles of neurons,  
e.g. synaptic processes and neural spiking

Try to infer something about

Changes in blood flow, oxygen concentration,  
blood volume

Changes in MRI contrasts due to changes in  
relative hemoglobin concentrations

Measured MRI signal

**1. What do we measure  
with MRI?**

Source, Huettel et al, 2004, fMRI (Book)



# 1. What do we measure with MRI?

- Magnetic resonance measures the collective signal of many spins (of protons, i.e. hydrogen atoms).
- The magnetic resonance depends on the properties of the nucleus and – most important – on its surrounding.

→ But how does it work?

# Material in a magnetic field

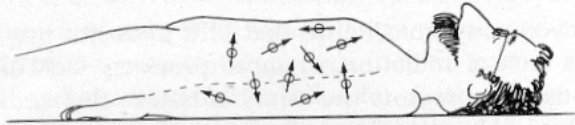

Figure 1-3 Under normal conditions, nuclear magnetic dipoles in the body are randomly distributed, which results in zero net magnetization.

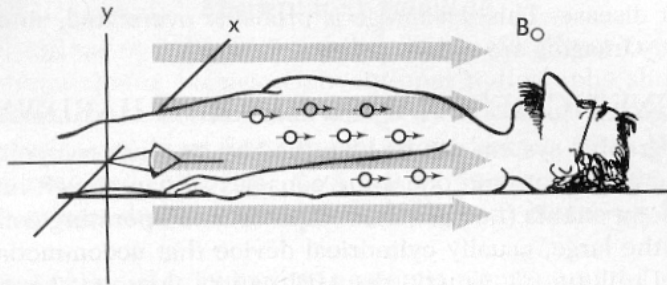
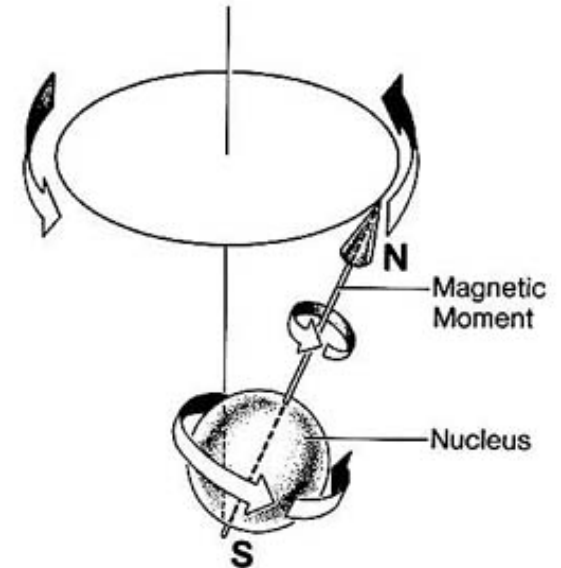

Figure 1-4 When a strong external magnetic field ( $B_0$ ) is applied, the patient becomes polarized and net magnetization ( $M$ ) appears.

Protons align with the magnetic field.

We can measure the average magnetization.



Spin = rotation of a proton  
around some axis

→ magnetic moment

Images: [www.fmri4newbies.com](http://www.fmri4newbies.com)

# Excitation and relaxation of spins



h RF pulse  
(MHz/Tesla).

Movies:  
K. Prüssmann

# Excitation and relaxation of spins



ed radio



Movies:  
K. Prüssmann

# Signal decay depends on tissue

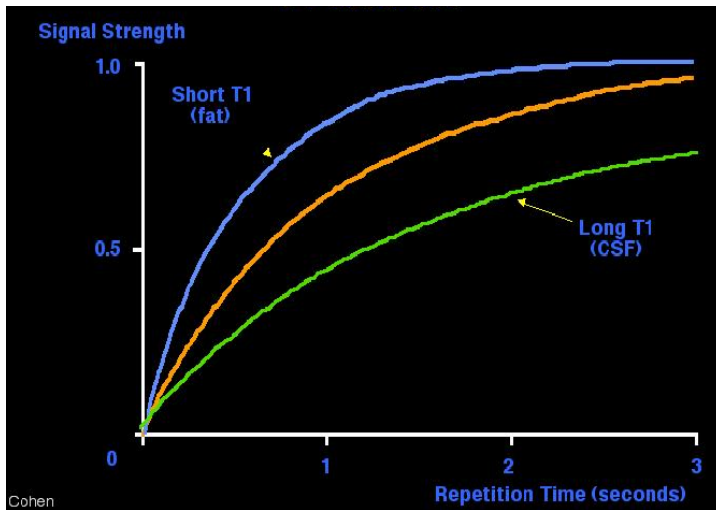

T1 = time constant of how quickly the protons realign with magnetic field

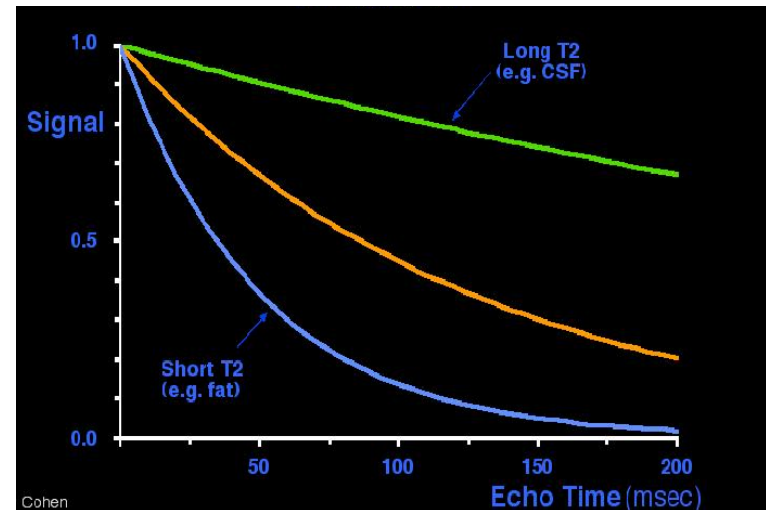

T2 = time constant of how quickly the protons dephase when recovering to equilibrium

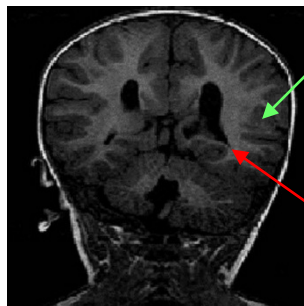

fat has high signal → bright

CSF has low signal → dark

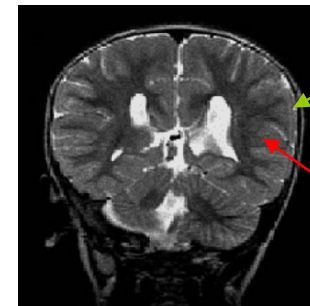

fat has low signal → dark

CSF has high signal → bright

Images:  
fmri4newbies.com

# Signal decay depends on tissue

T1 = How quickly do protons realign with magnetic field?

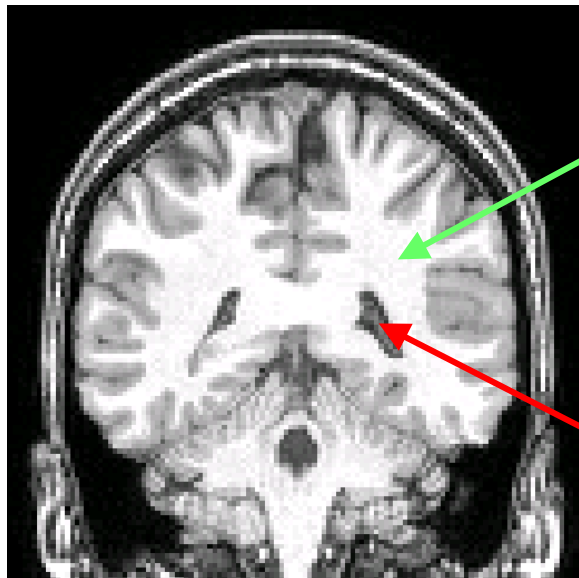

fat has high signal → bright

CSF has low signal → dark

T2 = How quickly do protons emit energy (phase out) when recovering to equilibrium?

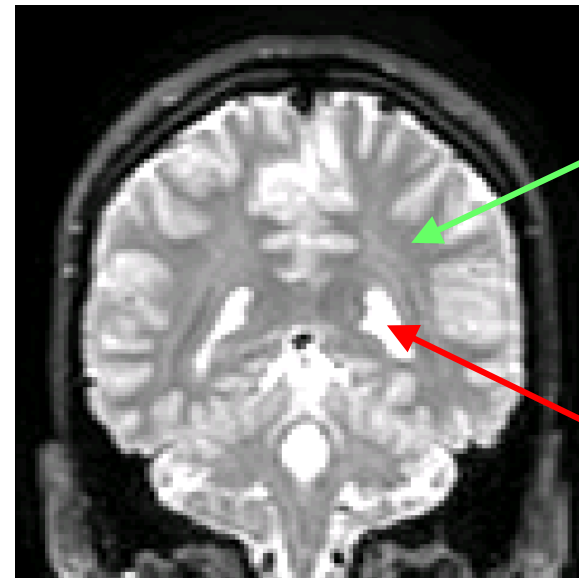

fat has low signal → dark

CSF has high signal → bright

# T2\* magnetization decay

- Decay of transverse magnetization has two factors:
  - 1) molecular interactions (tissue properties) (T2)
  - 2) local inhomogeneities of the magnetic field**
- The combined time constant is called T2\*.
- fMRI uses acquisition techniques (e.g. EPI) that are sensitive to changes in T2\*.

## The general principle of MRI:

- excite spins in static field by RF pulses & detect the emitted RF
- use an acquisition technique that is sensitive to local differences in T1, T2 or T2\*
- construct a spatial image

# 2. What do we measure with fMRI?

Cognitive processes (Sensory, motor, etc. )

Control and measure

Information processing in ensembles of neurons,  
e.g. synaptic processes and neural spiking

Try to infer something about

Changes in blood flow, oxygen concentration,  
blood volume

Changes in MRI contrasts due to changes in  
relative hemoglobin concentrations

**2. What do we measure  
with fMRI?**

Measured MRI signal

Source, Huettel et al, 2004, fMRI (Book)



# fMRI uses T2\* contrasts

- fMRI uses MRI sequences that measure T2\* decay of protons.
- Depends on:
  - Molecular interaction
  - **Local inhomogeneities of magnetic field**

# Fast acquisition of T2\*-weighted images

Mostly *echo planar imaging* (EPI)

**Sampling speed:**

1 slice: 50-100 ms → 2-4 secs per volume

**Spatial resolution:**

1-3 mm (standard 3 T scanner)

**Problems:**

- distortion and signal dropouts
- sensitive to head motion of subjects during scanning

→ **We need methods and statistics to deal with these problems!**

EPI  
(T2\*)

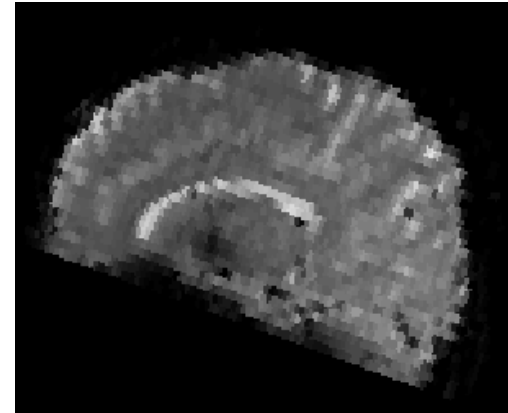

T1

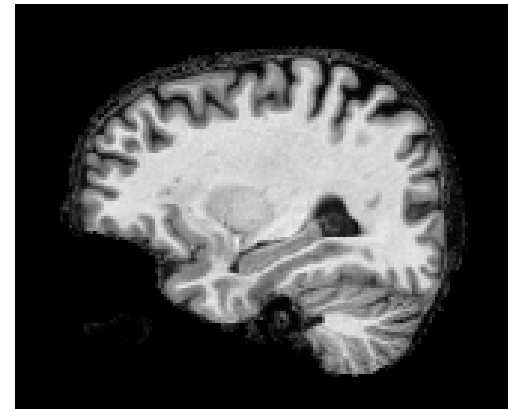

What makes T2\* weighted images “functional”?

# Magnetic properties of hemoglobin

210

CHEMISTRY: PAULING AND CORYELL

PROC. N. A. S.

## THE MAGNETIC PROPERTIES AND STRUCTURE OF HEMOGLOBIN, OXYHEMOGLOBIN AND CARBONMONOXYHEMOGLOBIN

BY LINUS PAULING AND CHARLES D. CORYELL

GATES CHEMICAL LABORATORY, CALIFORNIA INSTITUTE OF TECHNOLOGY

Communicated March 19, 1936

Oxygenated Hemoglobin (Hb)  
Diamagnetic

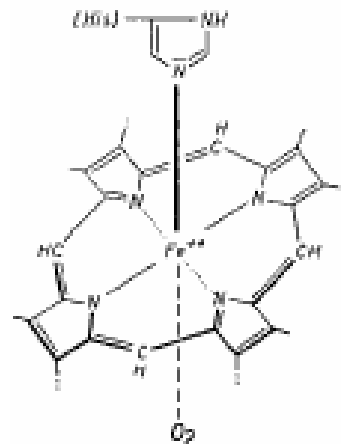

Deoxygenated Hemoglobin (dHb)  
Paramagnetic

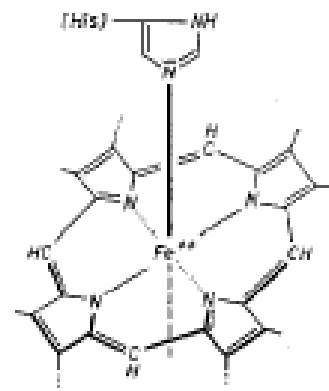

# Magnetic properties of oxy- and deoxy-hemoglobin

The more oxy-hemoglobin the larger (slower) is  $T_2^*$

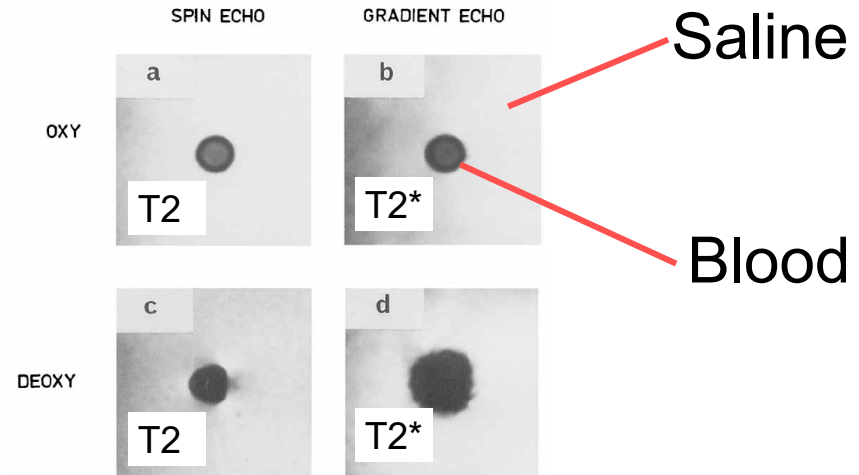
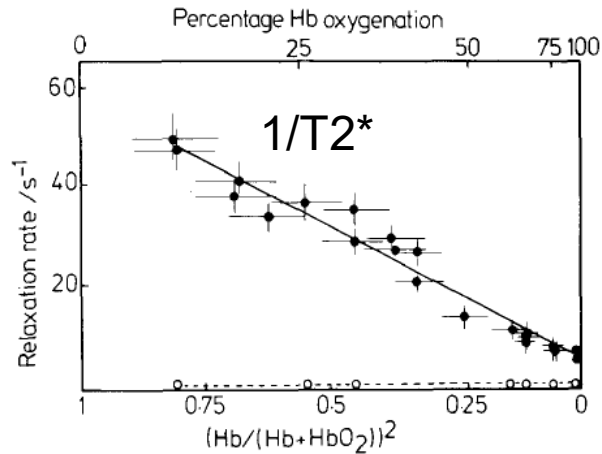

The signal comes from the susceptibility change due to deoxy-Hb vs. oxy-Hb.

OxyHb (diamagnetic) vs. DeoxyHb (paramagnetic) effects on spin of hydrogen atoms in surrounding tissue.

Source: Thulborn et al, Bioch. Biophys. Acta, 1981  
Ogawa et al, Magn. Res. Med., 1990

# The BOLD effect

- BOLD (Blood Oxygenation Level Dependent) contrast measures inhomogeneities in the magnetic field due to changes in the level of  $O_2$  in the blood

## **Oxygenated hemoglobin:**

Diamagnetic (non-magnetic)

→ no signal loss!

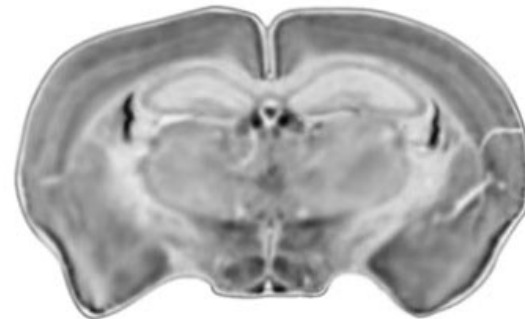

100 %  $O_2$

## **Deoxygenated hemoglobin:**

Paramagnetic (magnetic)

→ signal loss!

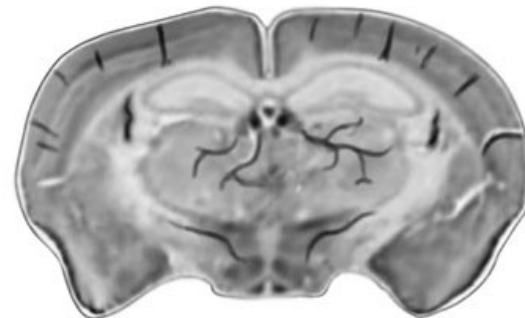

Normal air

Source: Ogawa et al, Magn. Res. Med., 1990

# Increased blood flow

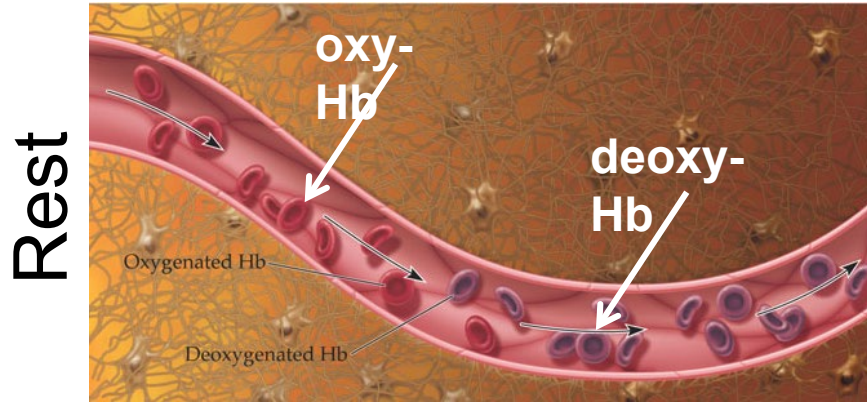

↑ neural activity → ↑ blood flow → ↑ oxyhemoglobin → ↑ T2\* → ↑ MR signal

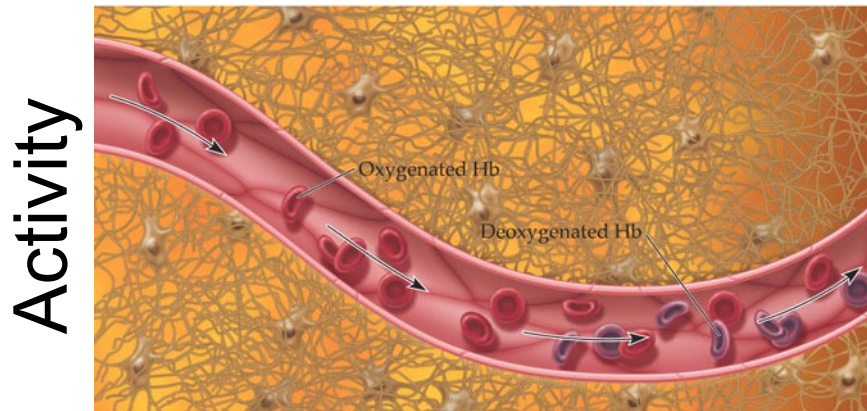

Source, Huettel et al, 2004, fMRI (Book)

# The BOLD signal

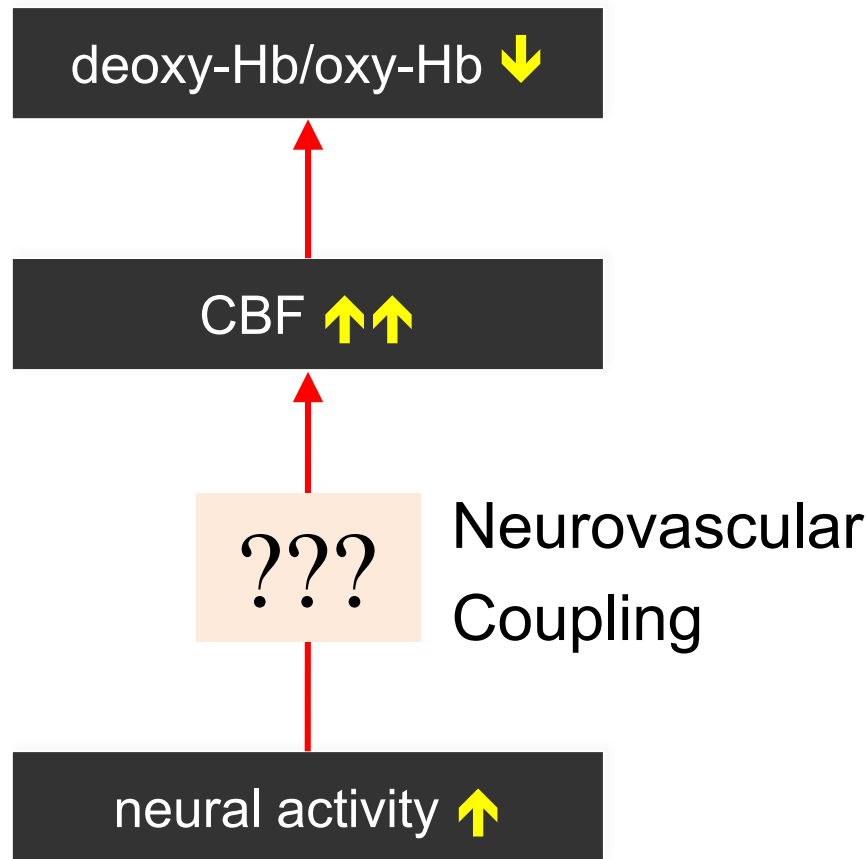

Increased neural activity leads to an over-compensatory increase of regional CBF, which decreases the relative amount of deoxy-Hb → higher T2\* signal intensity

# The BOLD signal

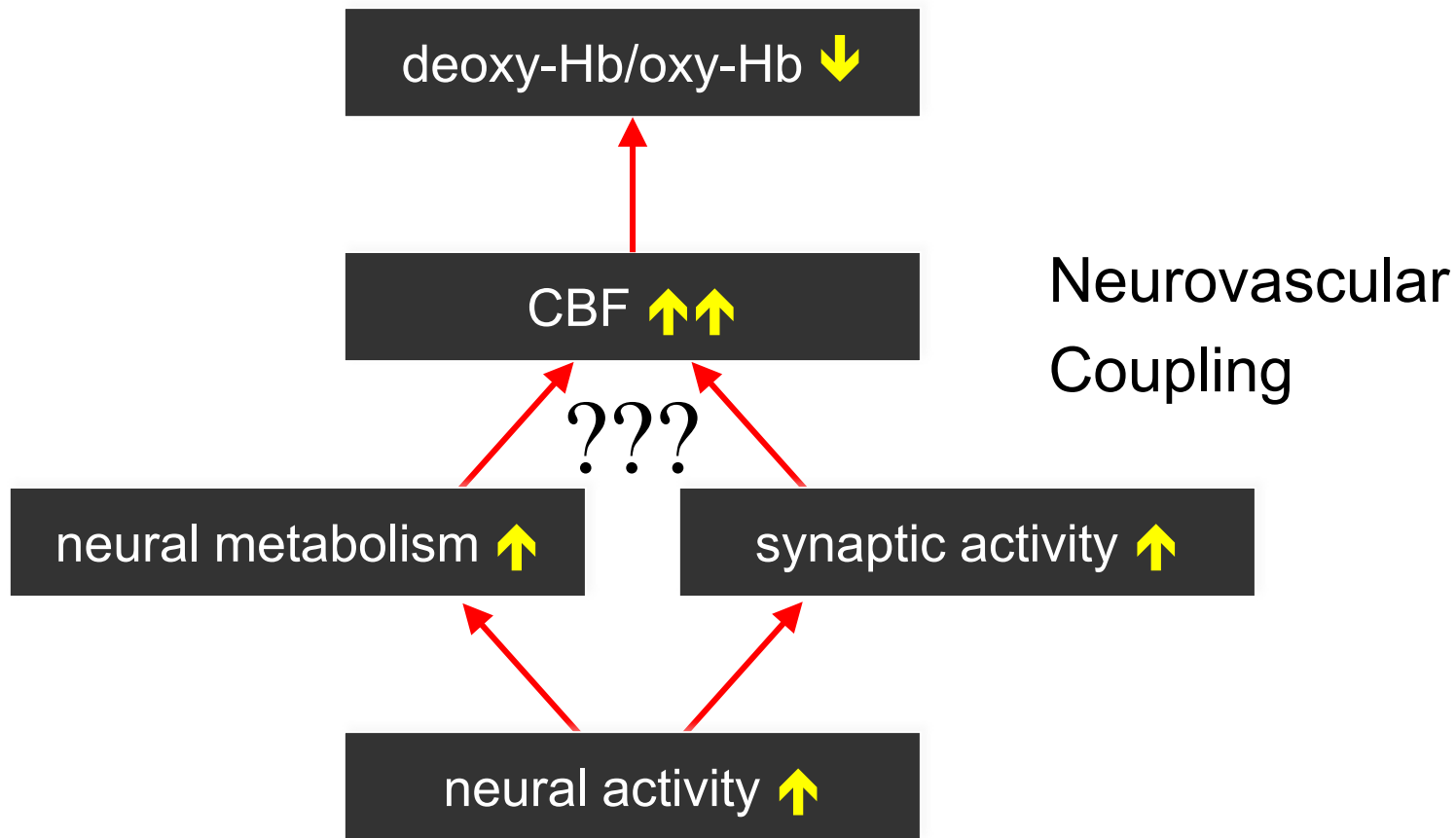

Increased neural activity leads to an over-compensatory increase of regional CBF, which decreases the relative amount of deoxy-Hb → higher T2\* signal intensity



# Properties of the hemodynamic response function (HRF)

sometimes shows initial undershoot → initial dip

peaks after 4-6 secs

back to baseline after approx. 30 secs

can vary between regions and subjects

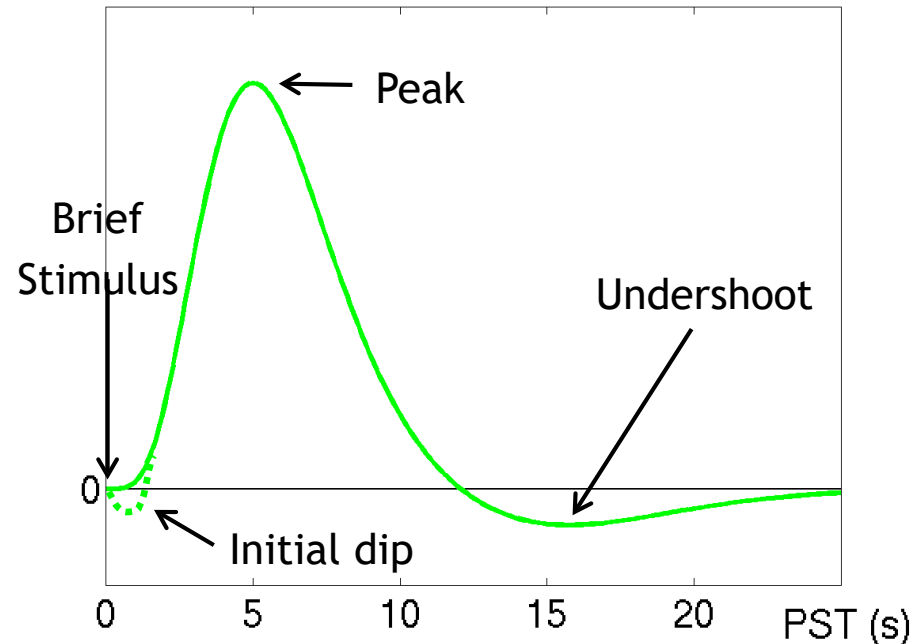

Hemodynamic response function (HRF) =  
BOLD response to a brief stimulus

# Approximation of HRF with linear transform?

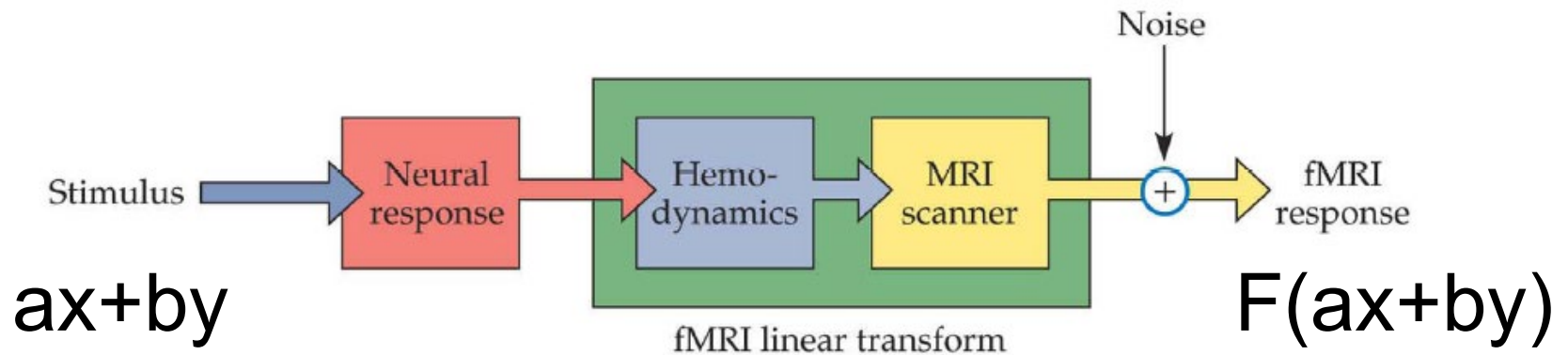

$$F(ax+by) = aF(x) + bF(y)$$

Source: Huettel et al, 2004, fMRI (Book)

# Evidence for linearity from early experiments

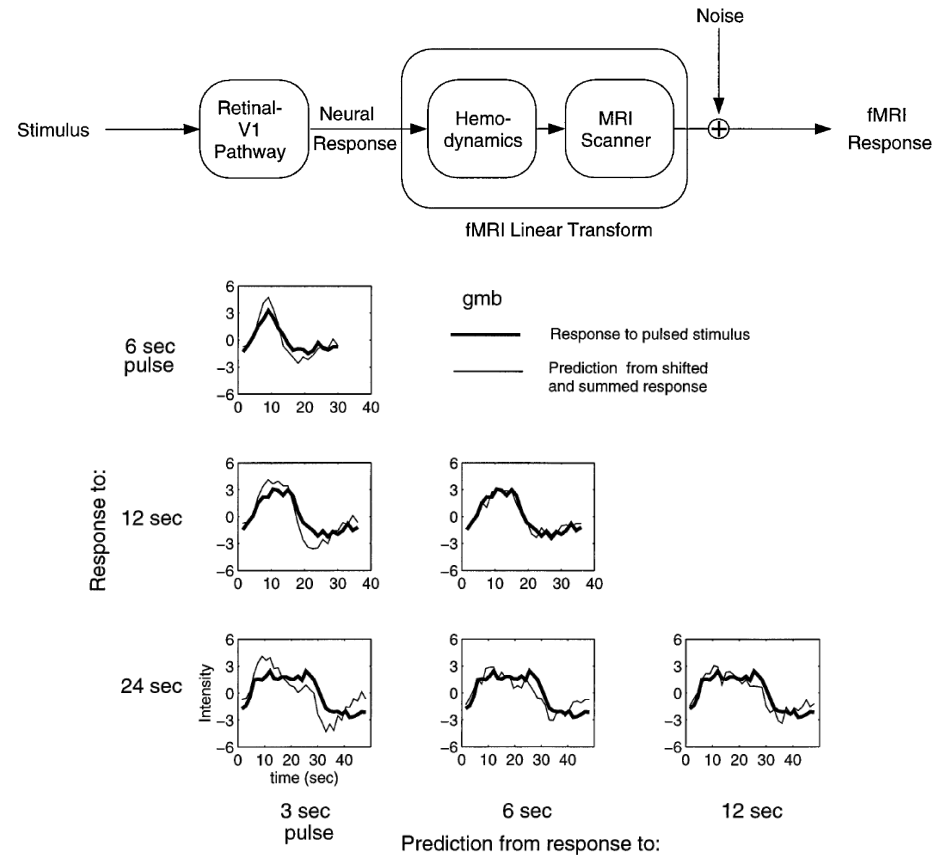
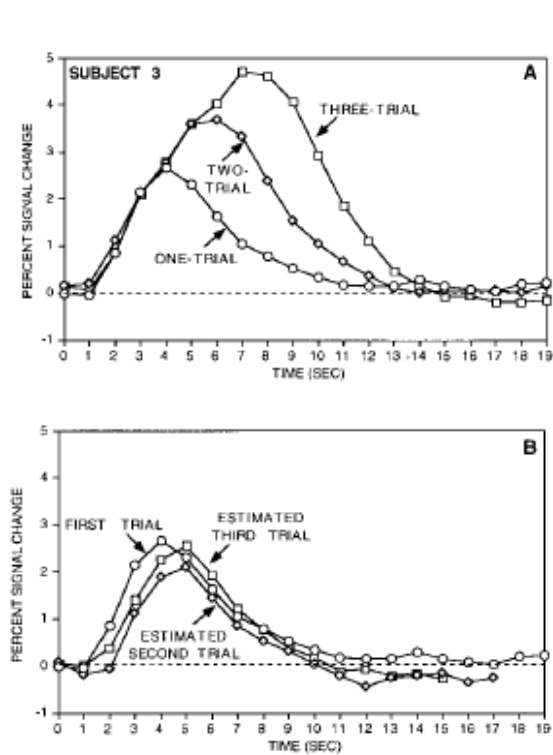

Although the HRF is non-linear, it is often a good approximation to consider the HRF being a linear transform.

Source: Dale and Buckner, Hum Brain Mapp, 1997; Boynton et al, J Neurosci, 1996

# BOLD is a non-linear function of rCBF

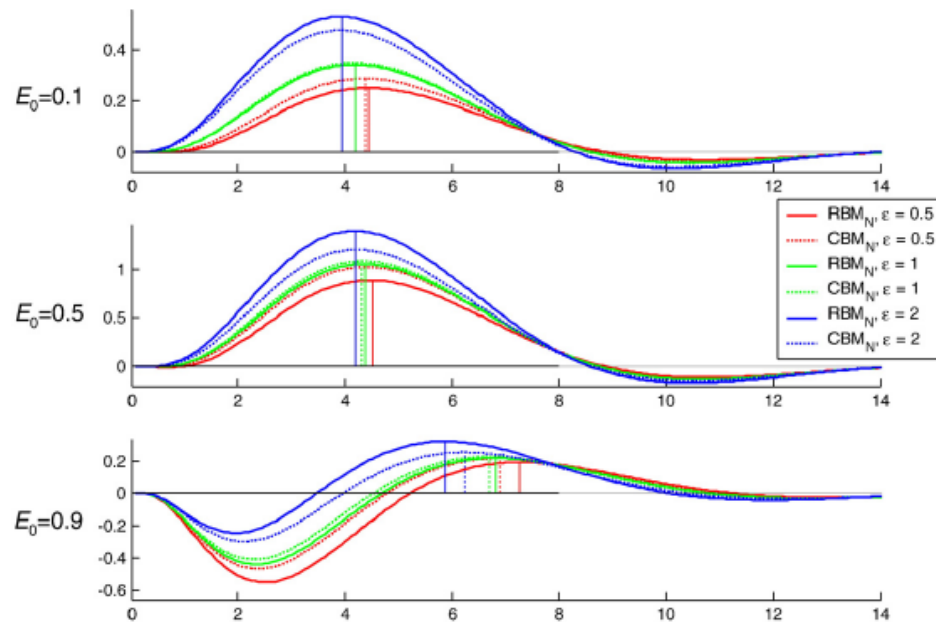
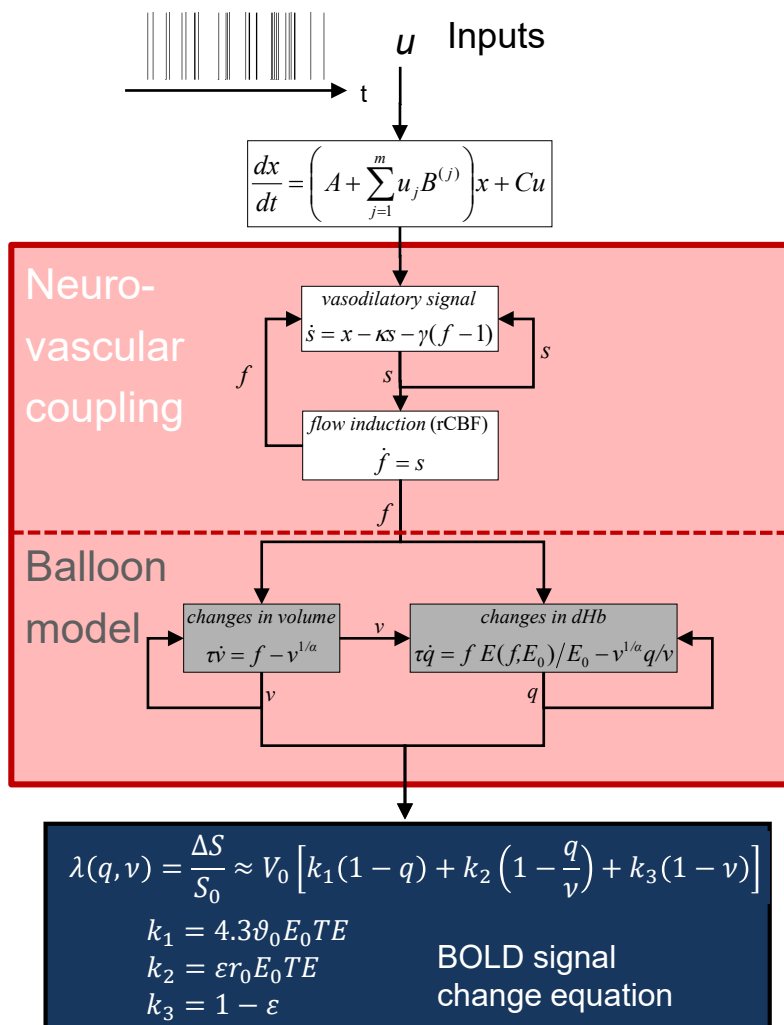

- Blood volume and deoxy-hemoglobin concentration are important
- cf. DCM in part 2.

Source: Stephan et al., NeuroImage, 2007

# 3. How is the BOLD signal related to neural activity?

Cognitive processes (Sensory, motor, etc. )

Control and measure

Information processing in ensembles of neurons,  
e.g. synaptic processes and neural spiking

Try to infer something about

**3. How is the BOLD signal  
related to neural processing?**

Changes in blood flow, oxygen concentration,  
blood volume

Changes in MRI contrasts due to changes in  
relative hemoglobin concentrations

Measured MRI signal

Source, Huettel et al, 2004, fMRI (Book)

# 3. How is the BOLD signal related to neural activity?

## Three important questions:

1. Which electrophysiological measure is best reflected by the BOLD signal - neuronal action potentials or local field potentials (LFP)?
2. Does the BOLD signal reflect energy demands or synaptic activity?
3. What does a negative BOLD signal mean?

# Where does the signal come from: Soma or synapse?

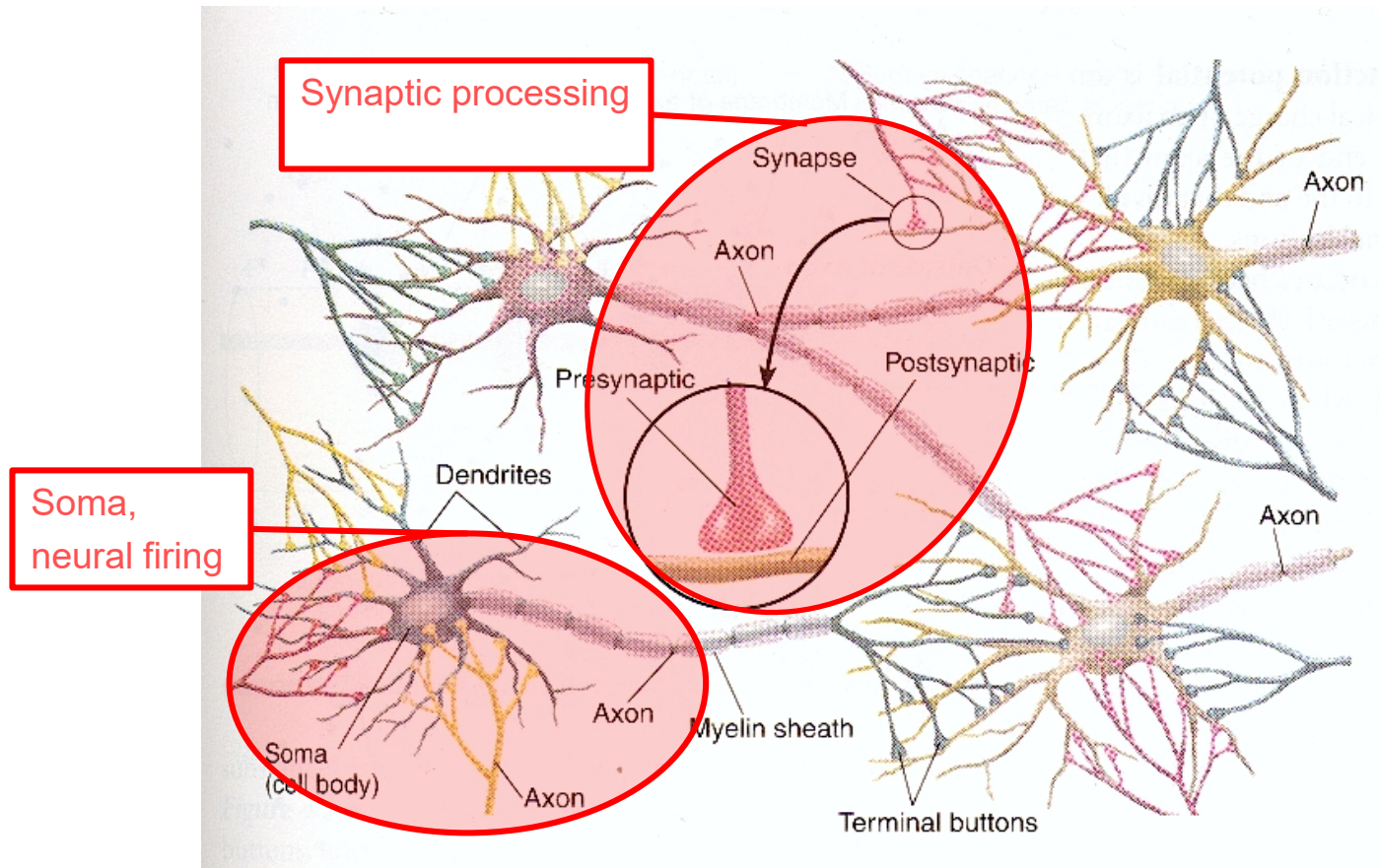

Source: <http://psychology.uwo.ca/fmri4newbies/Tutorials.html>

# Comparing BOLD with electrophysiology – early experiments

Moving dot stimuli

Compare average monkey physiology to average BOLD signal in humans.

Is the average firing rate of cells in monkey MT related to the BOLD activity measured in humans.

→ There is a good agreement between spiking (firing rate) and BOLD.

1% signal change  $\approx$  9 spikes/second

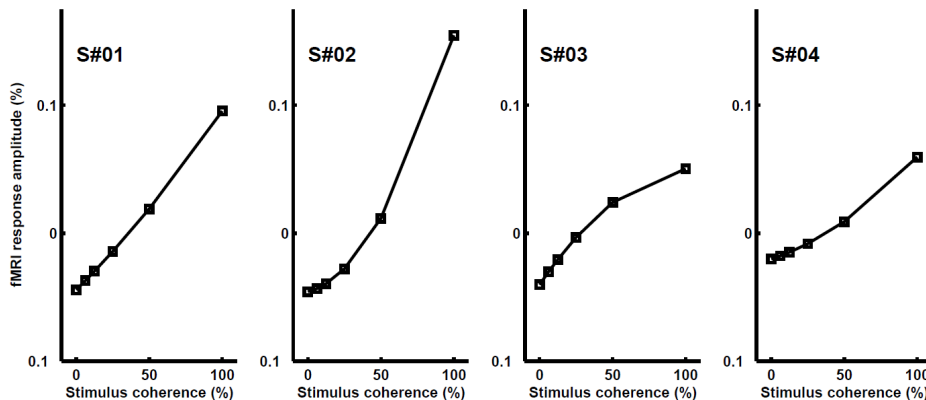

Similarly, for contrast in V1

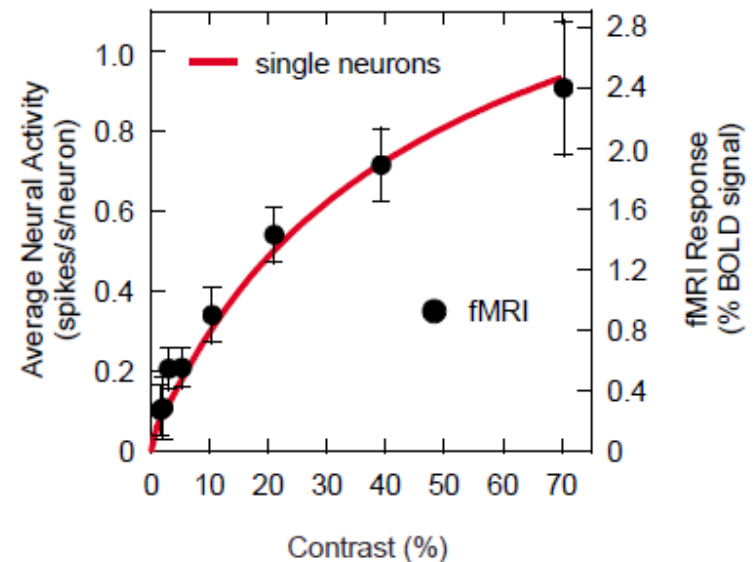

Source: Heeger et al, Nat Neurosci, 2000;  
Rees et al, Nat Neurosci, 2000



# MUA/LFP and BOLD

combined BOLD fMRI and electrophysiological recordings

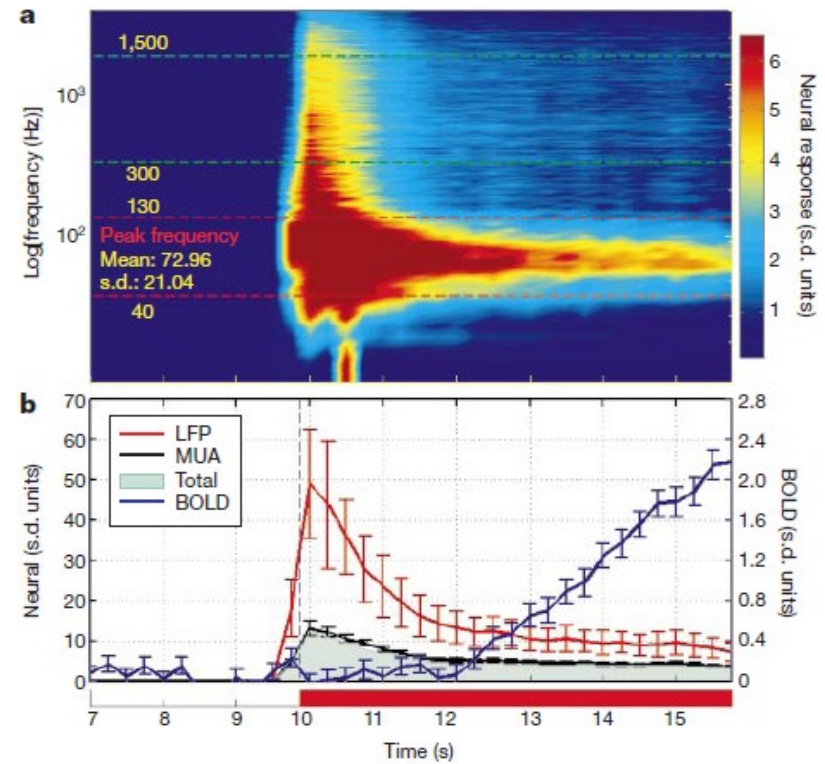
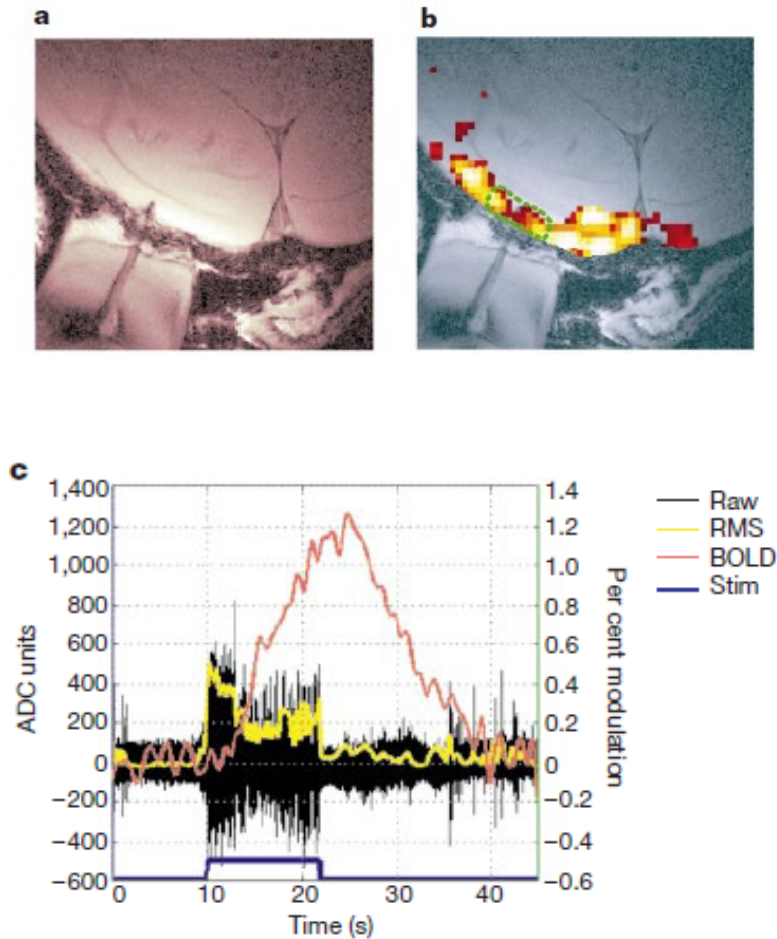

Source: Logothetis et al, Nature, 2001

# LFP correlates best with the BOLD-signal

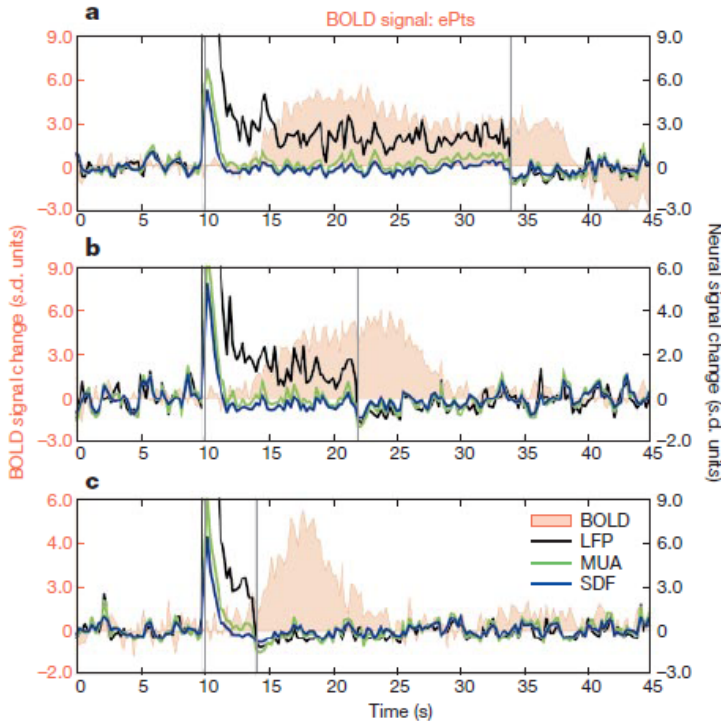

→ found that BOLD activity is more closely related to LFPs than MUA

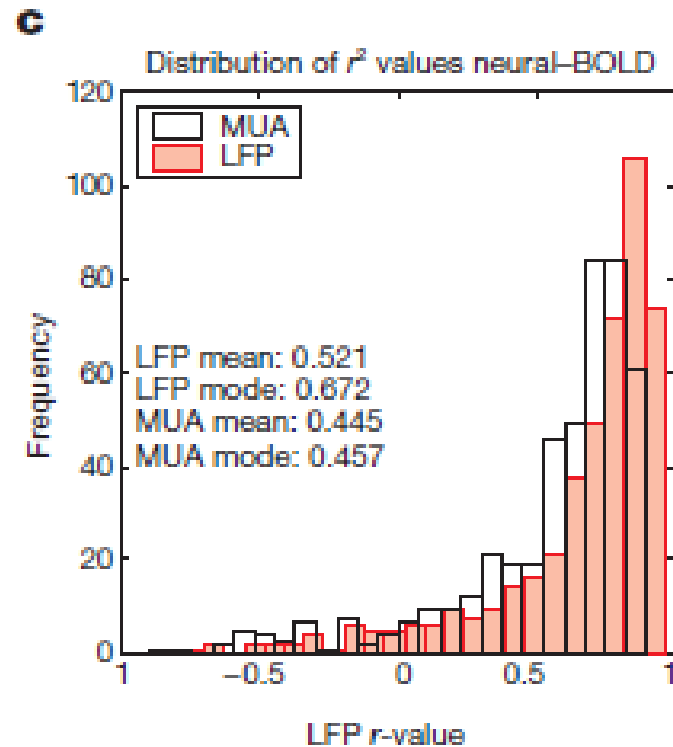

## Local Field Potentials (LFP)

- reflect summation of post-synaptic potentials

## Multi-Unit Activity (MUA)

- reflects action potentials/spiking

Source: Logothetis et al, Nature, 2001

# The debate continuous

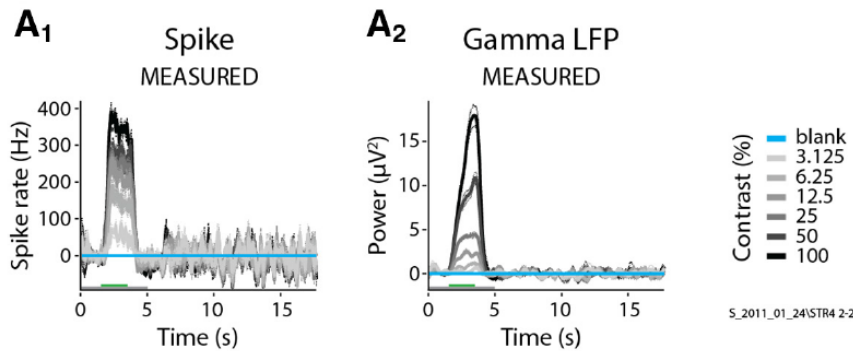

Imaging

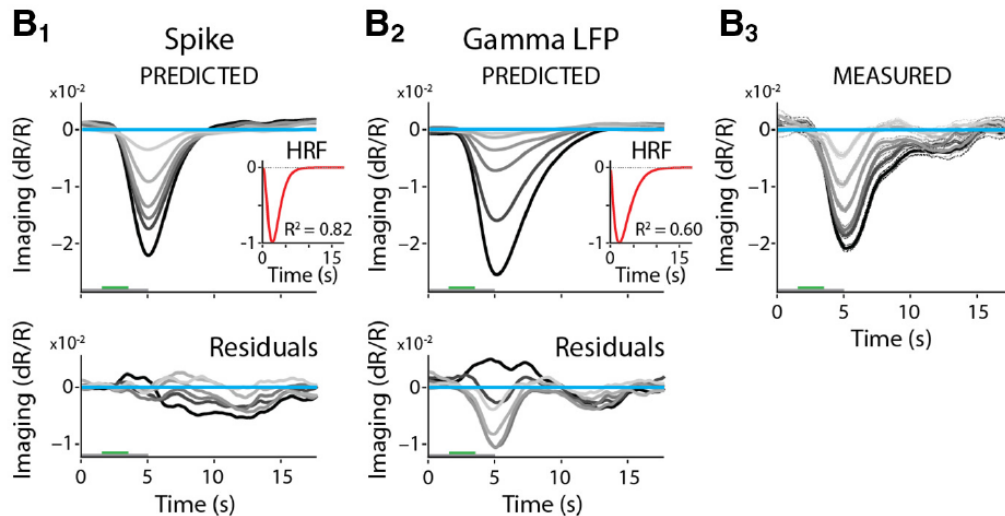

- response to visual stimuli of varying contrast.
- used optical imaging instead of fMRI.
- removed blank trials

→ Spikes predict imaging better than LFP.

Source: Lima et al, J Neurosci, 2014

# The BOLD signal is correlated to postsynaptic activity

- The BOLD is correlated to both LFPs and spikes.
  - Controversy goes on: which of the two is more closely linked?
  - rCBF-increase can be independent from spiking activity, but so far no case has been found where it was independent of LFPs.
- Present conclusion of the field: BOLD more strongly reflects the **input to** a neuronal population as well as its **intrinsic processing**, rather than its spiking output.
  - Final decision is not taken yet.

# 3. How is the BOLD signal related to neural activity?

## Three important questions:

1. Is the BOLD signal more strongly related to neuronal action potentials or to local field potentials (LFP)?
2. Does the BOLD signal reflect energy demands or synaptic activity?
3. What does a negative BOLD signal mean?

# What drives the BOLD signal?

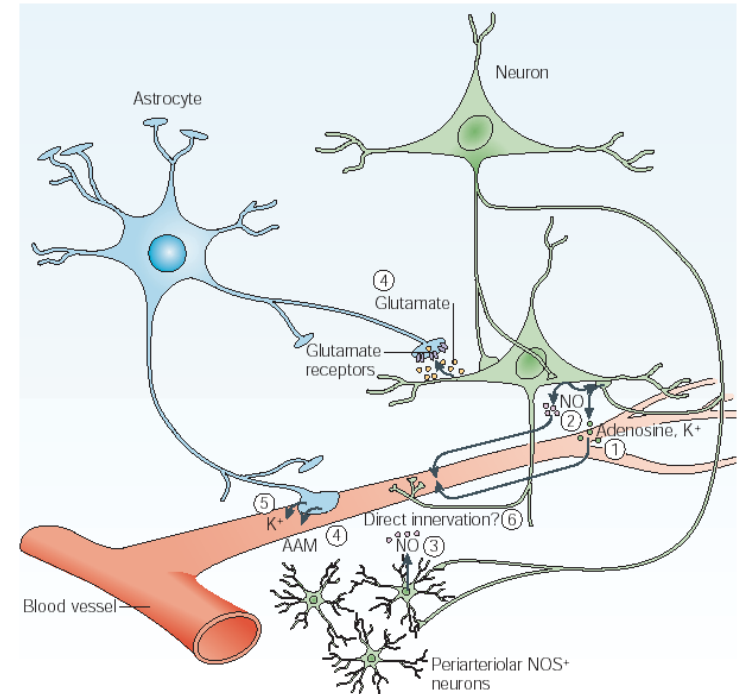
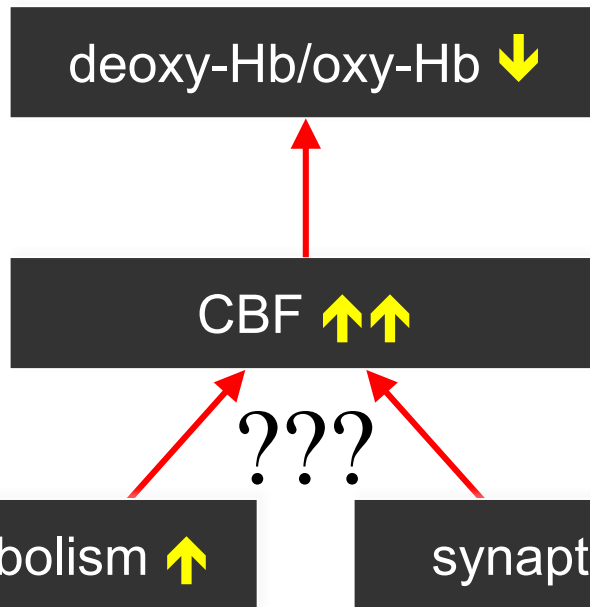

# Cortical Metabolism

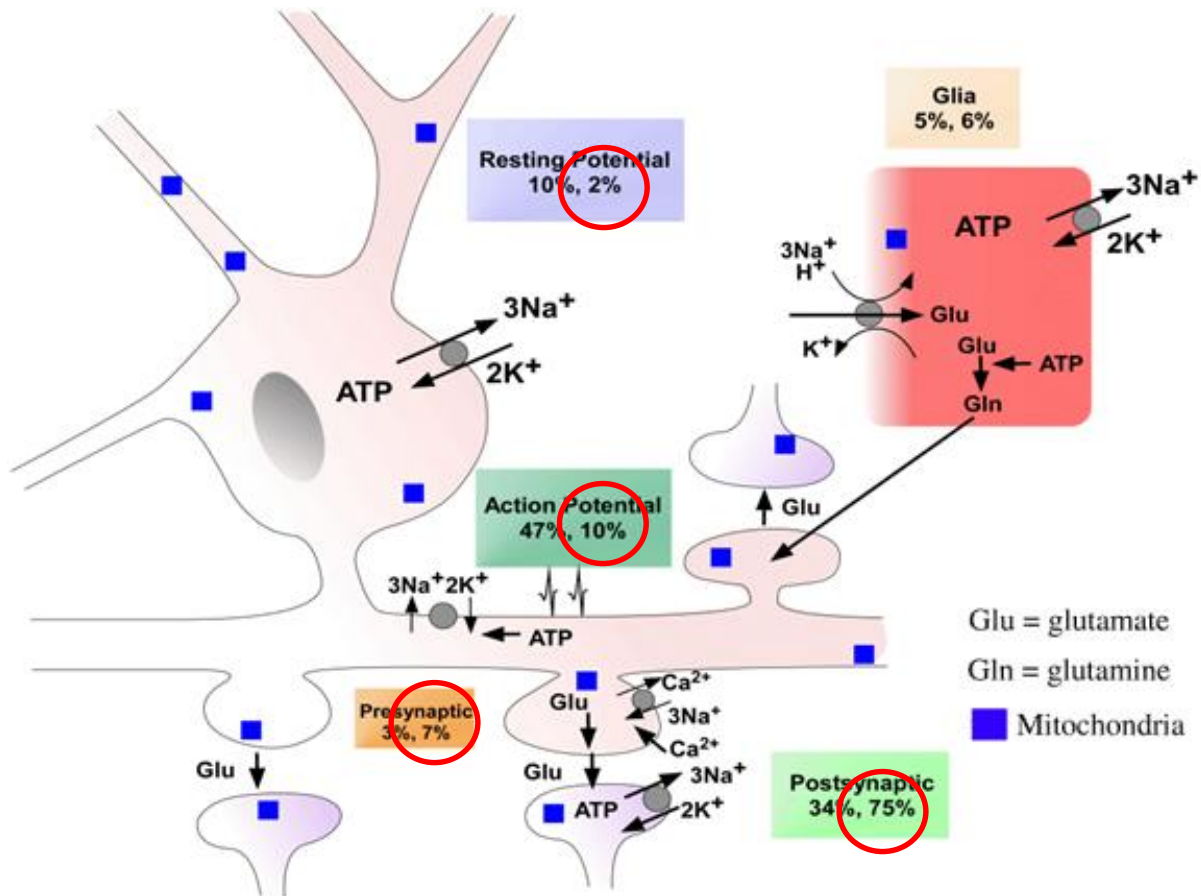

<http://student.biology.arizona.edu/honors99/group7/glycolysis.jpg>  
 Based on: Attwell and McLaughlin, J Cer. Blood Flow Metab, 2001

# Localisation of neuronal energy consumption

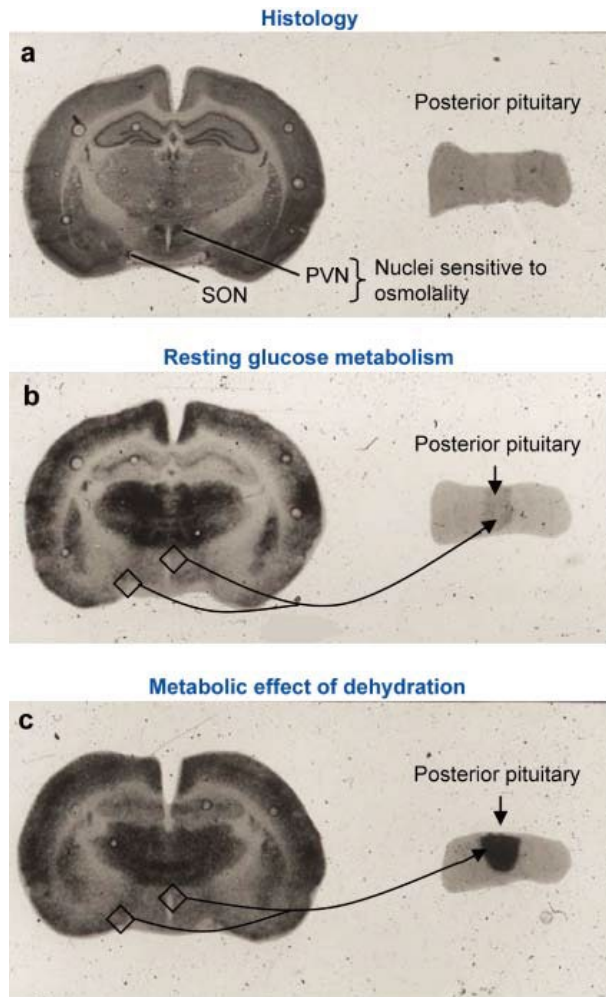

Salt loading in rats and 2-deoxyglucose mapping

→ glucose utilization in the posterior pituitary but not in paraventricular and supraoptic nuclei (which release ADH & oxytocin at their axonal endings in the posterior pituitary)

→ neuronal energy consumption takes place at the synapses, not at the cell body

Schwartz et al., Science, 1979



# Excitatory action might directly regulate rCBF

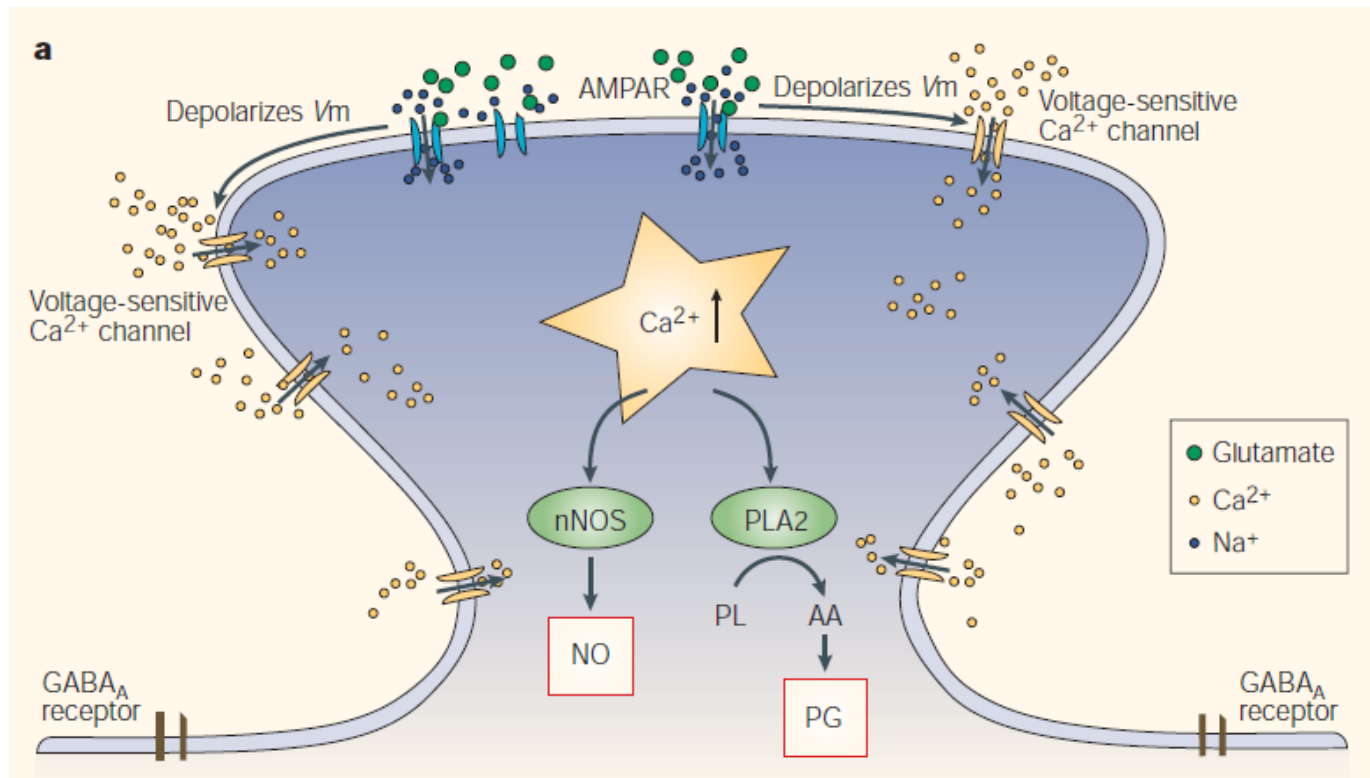

NO (nitric oxid) and PG (prostaglandin) have vasodilatory effects

→ Importance of Calcium

But: Very little contact between neurons and vasculature.

Source: Lauritzen, Nat Rev. Neurosci, 2005

# Glia cells and blood supply

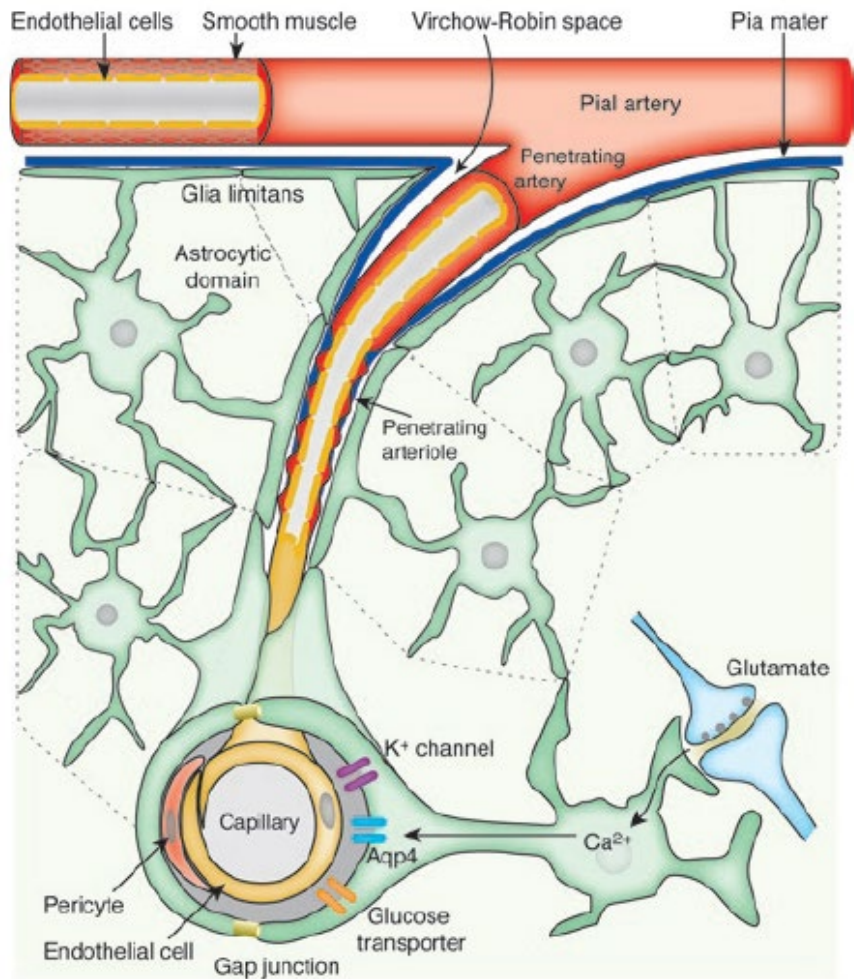

Astrocytes have many contacts with blood vessels.

Glia limitans can regulate blood flow of larger vessels

Domains of astrocytes are in line with a potential function in regulating blood flow.

Source: Iadecola and Nedergaard, Nat Rev Neurosci, 2007

# Several pathways for blood flow regulation

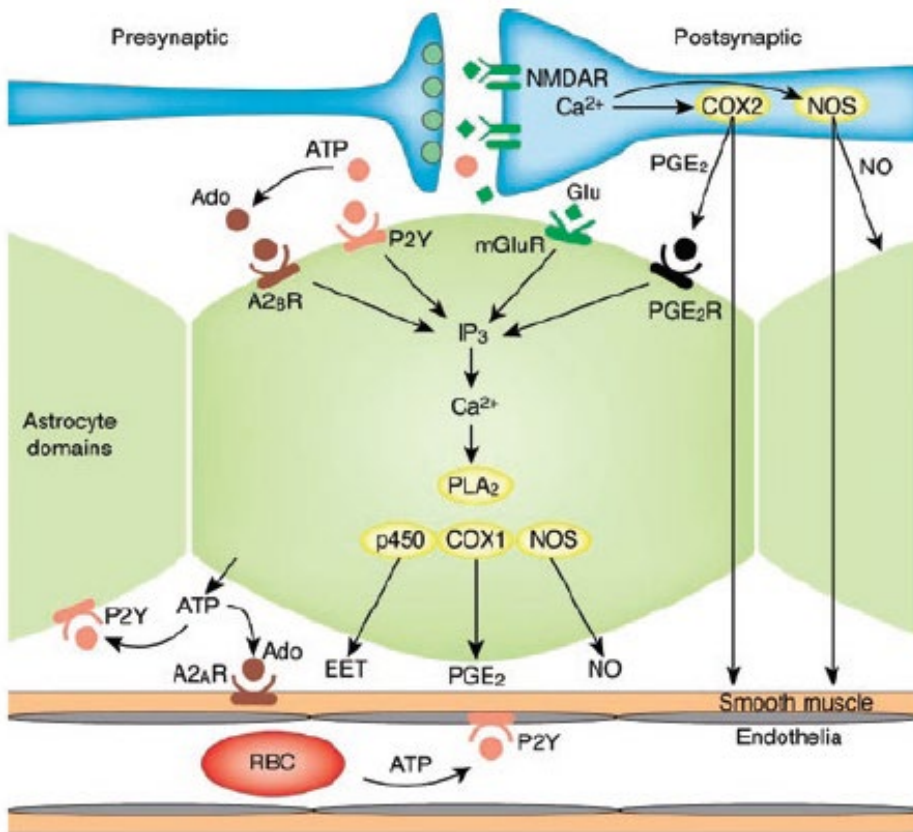

Forward control of blood flow seems to occur via several mechanisms.

To date, two major pathways have been associated with NO and PG.

Astrocytes are important.

Source: Iadecola and Nedergaard, Nat Rev Neurosci, 2007

# 3. How is the BOLD signal related to neural activity?

## Three important questions:

1. Is the BOLD signal more strongly related to neuronal action potentials or to local field potentials (LFP)?
2. Does the BOLD signal reflect energy demands or synaptic activity?
3. What does a negative BOLD signal mean?

# Negative BOLD is correlated with decreases in LFPs

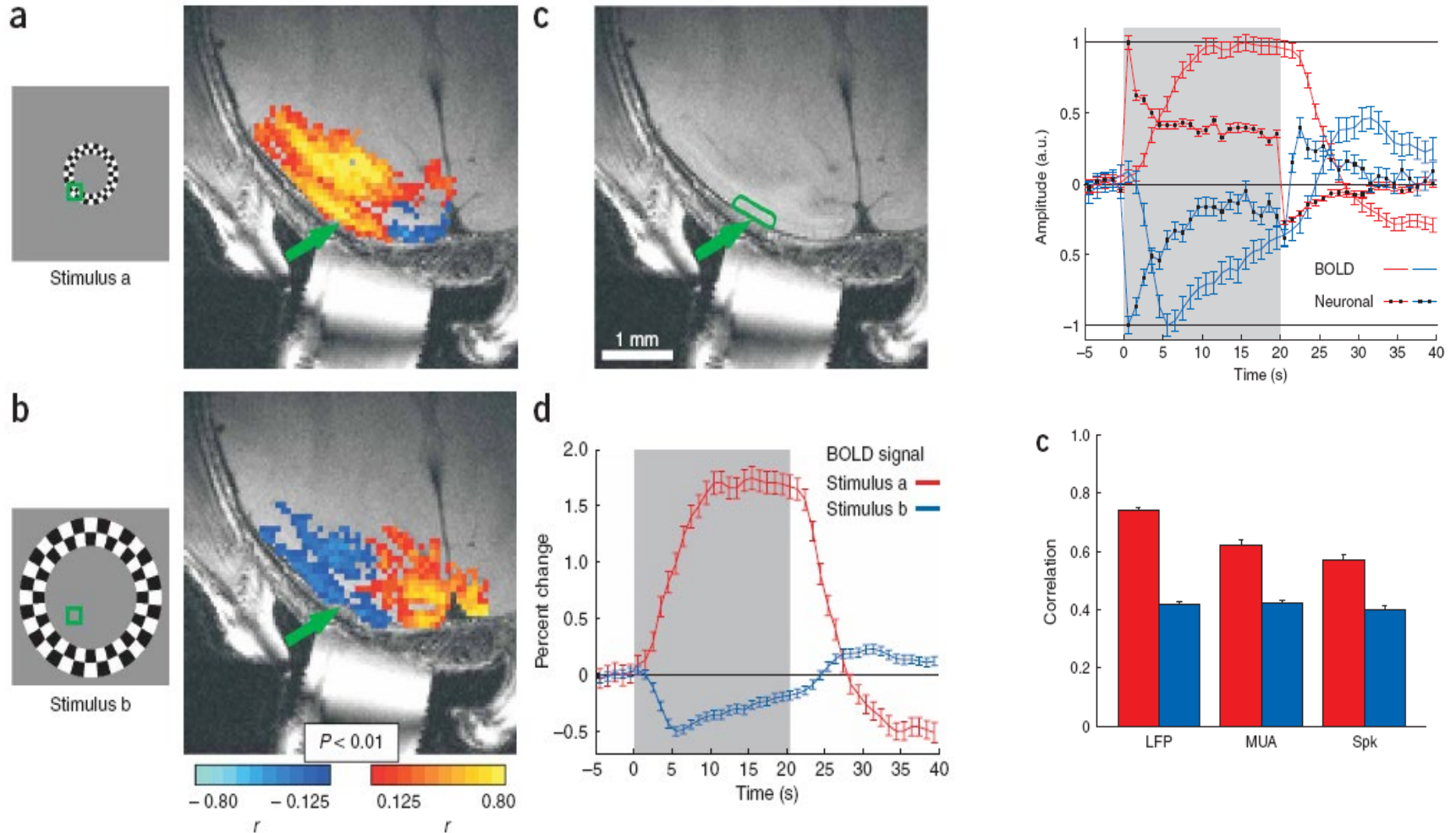

Shmuel et al., Nat Neurosci, 2006

# Impact of inhibitory postsynaptic potentials (IPSPs) on blood flow

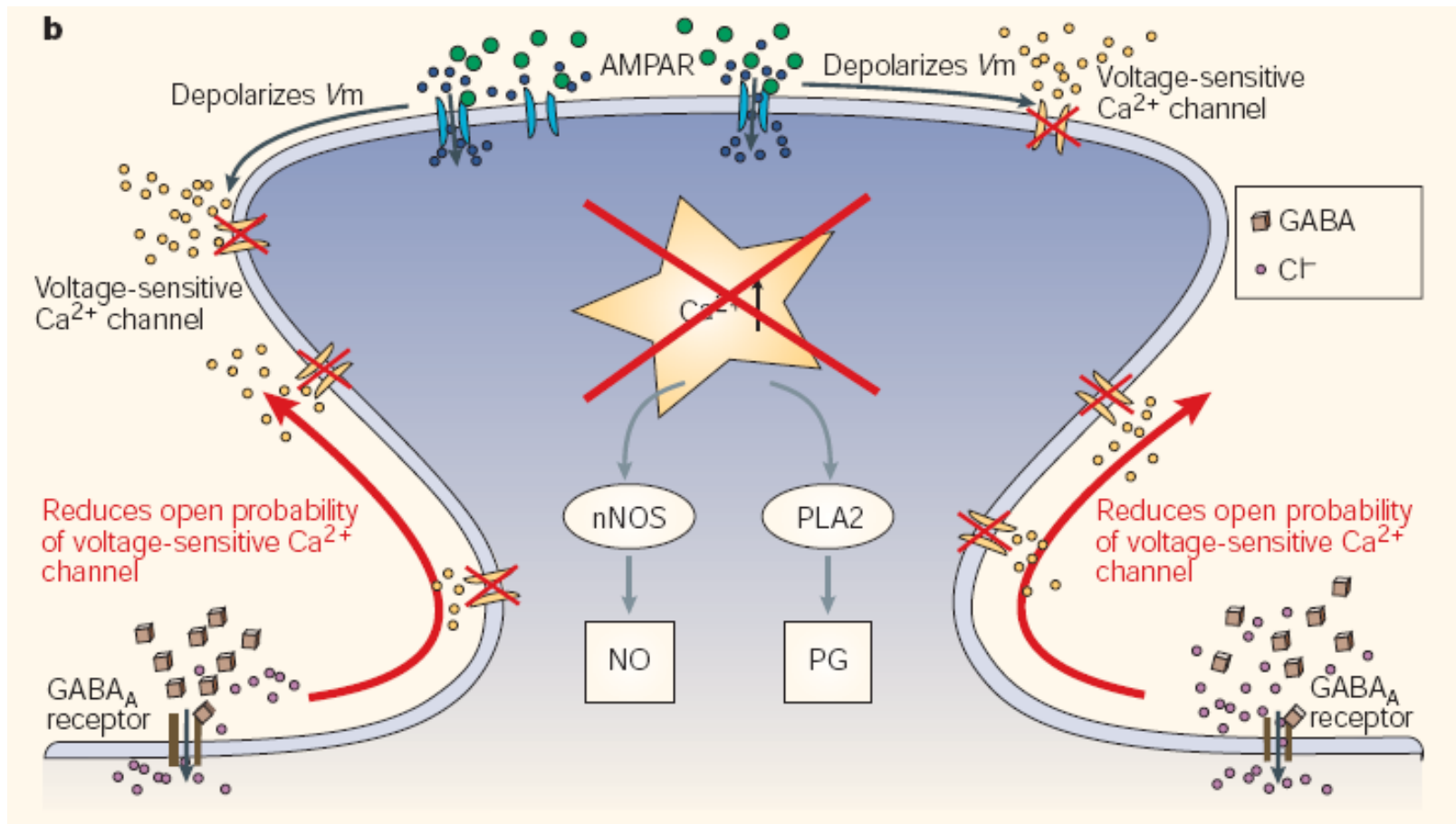

Source: Lauritzen, Nat Rev. Neurosci, 2005

# Excitatory-inhibitory networks and BOLD

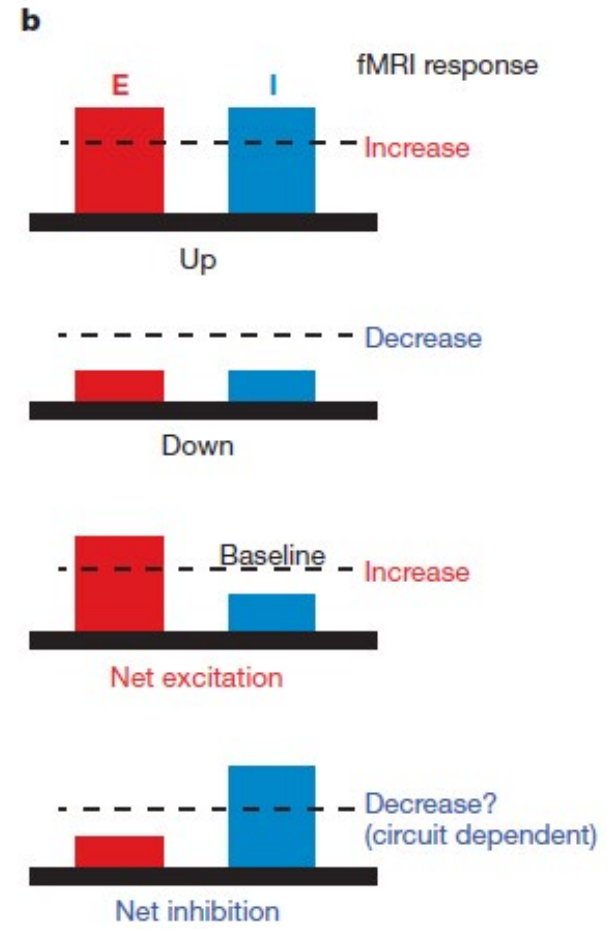
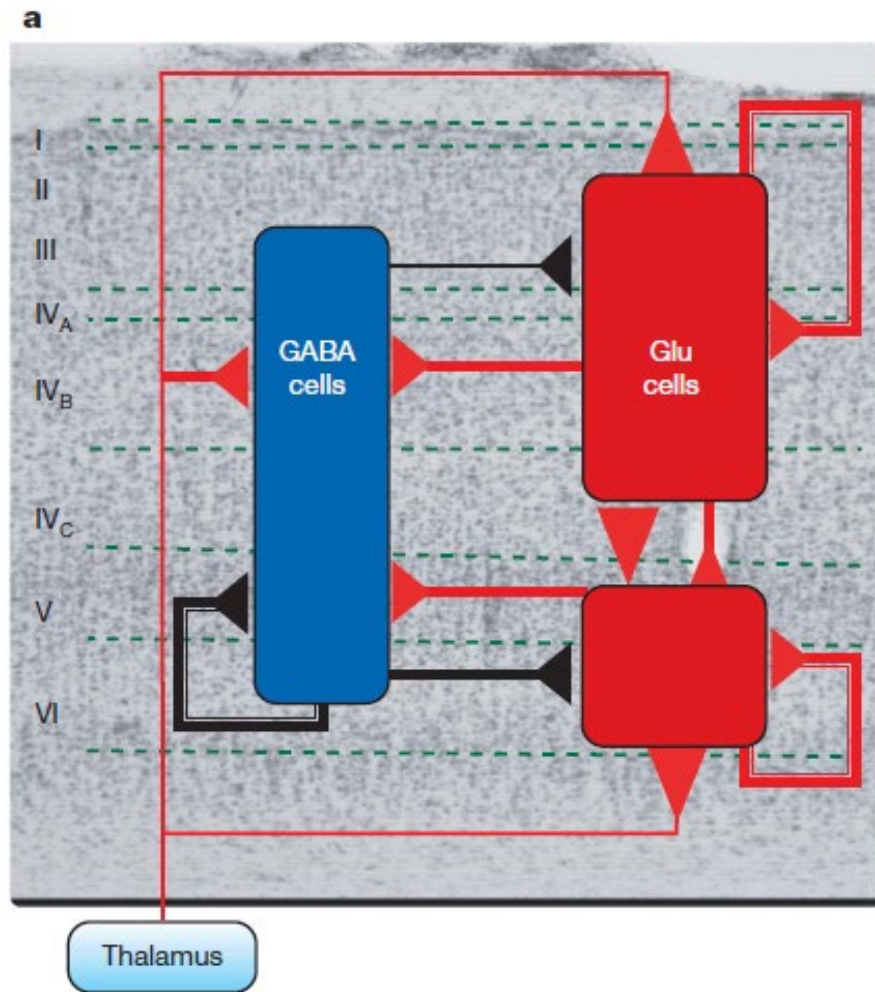

Source: Logothetis, Nature, 2008

# BOLD Summary

- The BOLD signal seems to be more strongly related to LFPs than to spiking activity (ongoing controversy).
  - The BOLD signal may primarily reflect the input to a neuronal population as well as its intrinsic processing.
- Blood flow seems to be controlled in a forward fashion by postsynaptic processes leading to the release of vasodilators (e.g., NO and prostaglandines).
- Negative BOLD signals may result from IPSPs.
- Various drugs can interfere with the BOLD response.
- We are far from completely understanding neurovascular coupling!



# Summary Overview

1. MRI measures the decay of magnetization of protons which depends on tissue properties.
2. fMRI measures changes in magnetic properties due to the ratio of oxy- vs. deoxy-hemoglobin in cerebral blood.
3. The BOLD signal is locally best correlated to the local field potential, which is itself highly correlated to spiking.

# Thank you!

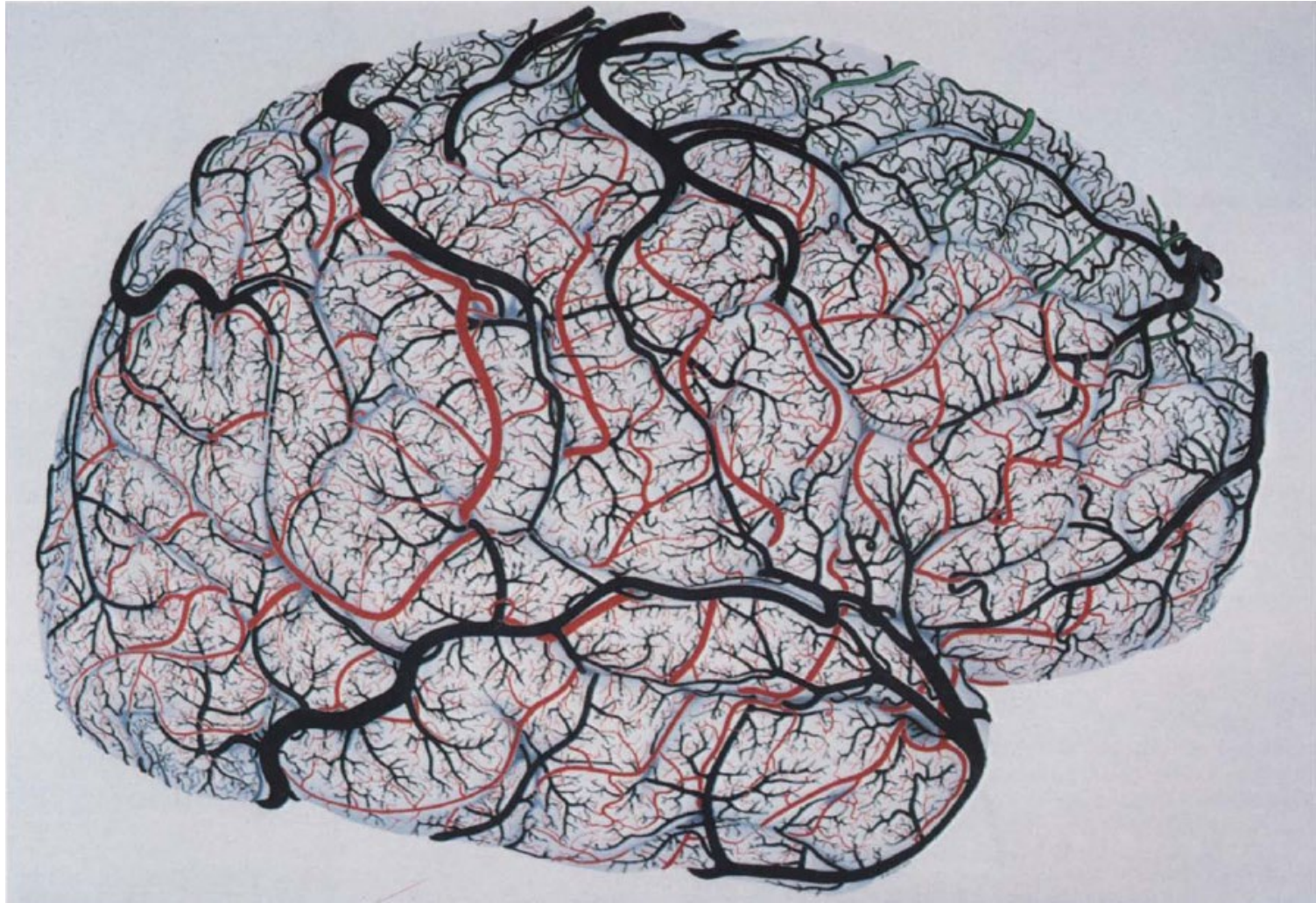

Source: Duvernoy et al, Brain Res. Bull., 1981

# More Information

- McRobbie et al, From Picture to Proton, Cambridge University Press, 2007
- Huettel et al, Functional Magnetic Resonance Imaging, Sinauer, 2004
- Logothetis and Wandell, Ann. Rev. Neurosci., 2004 (BOLD in general)
- Logothetis et al, Nature, 2001 (LFP vs. BOLD)
- Logothetis, Nature, 2008 (What can we do with BOLD? What not?)
- Lauritzen, Nat. Rev. Neurosci., 2005 (Calcium, Bold in Cerebellum)
- Iadecola and Nedergard, Nat. Neurosci., 2007 (Glia cells)
- <http://psychology.uwo.ca/fmri4newbies/Tutorials.html>

# Additional slides

The following slides contain additional material with references to papers. These are interesting papers and topics, but will not be part of the exam.

# Dissociation between action potentials and rCBF

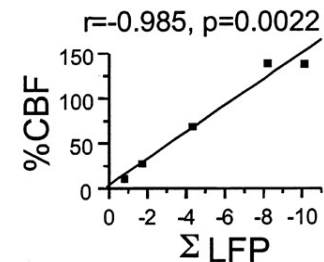
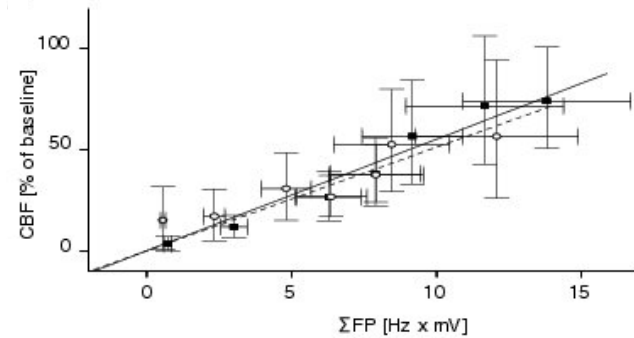
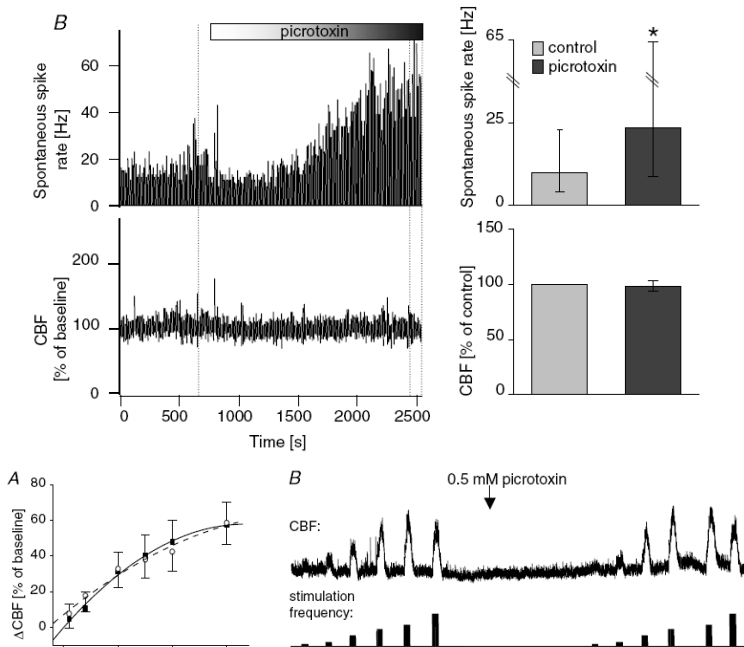

- GABA<sub>A</sub> antagonist picrotoxin increased spiking activity without increase in rCBF...
- ... and without disturbing neurovascular coupling per se

⇒ rCBF-increase can be independent from spiking activity, but seems to be always correlated to LFPs

Source: Thomsen et al., J Physiol, 2004

Lauritzen & Gold, J Neurosci, 2003

# Relation of BOLD and electrophysiology

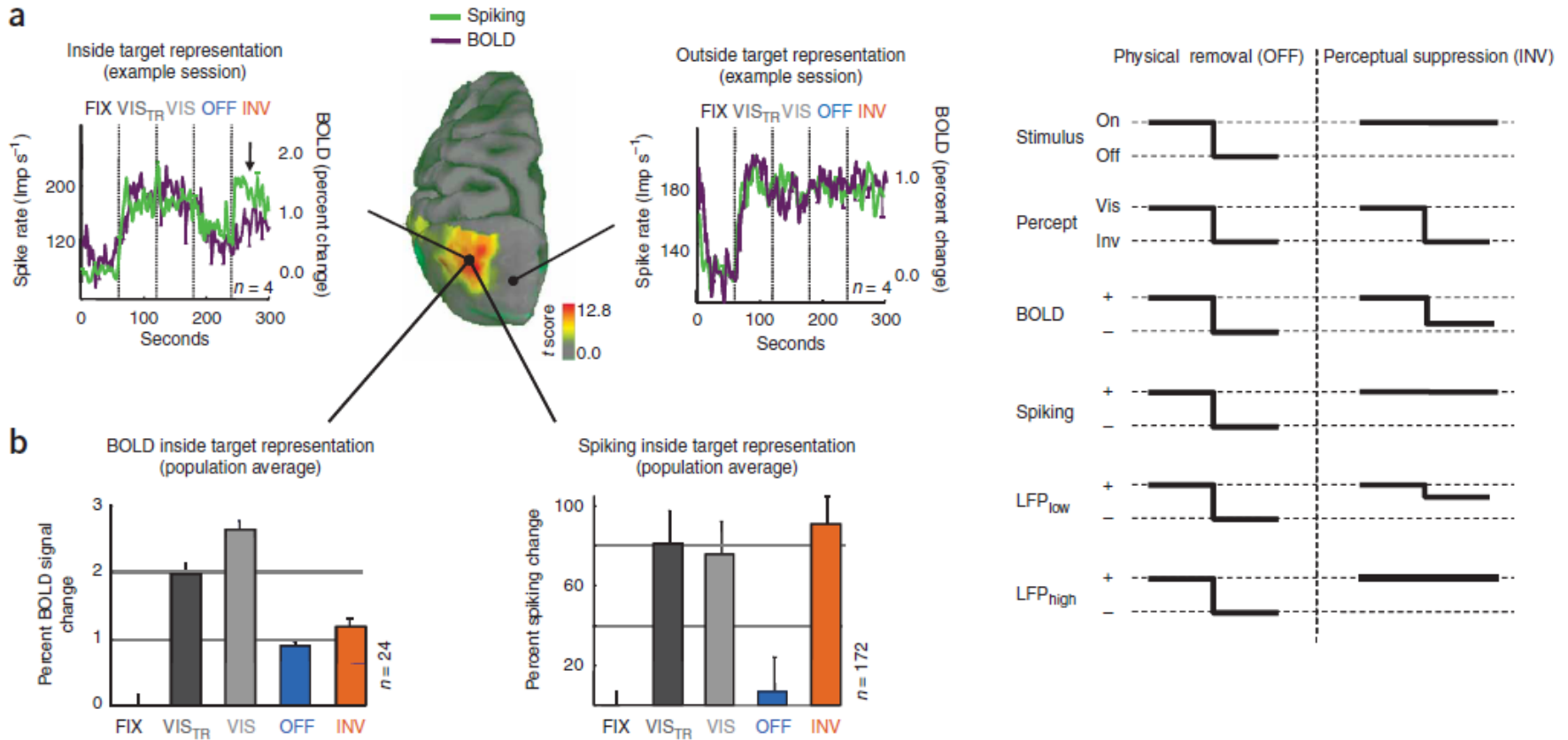

Source: Maier et al, Nat Neurosci, 2008

# Influence of oxygen on blood control

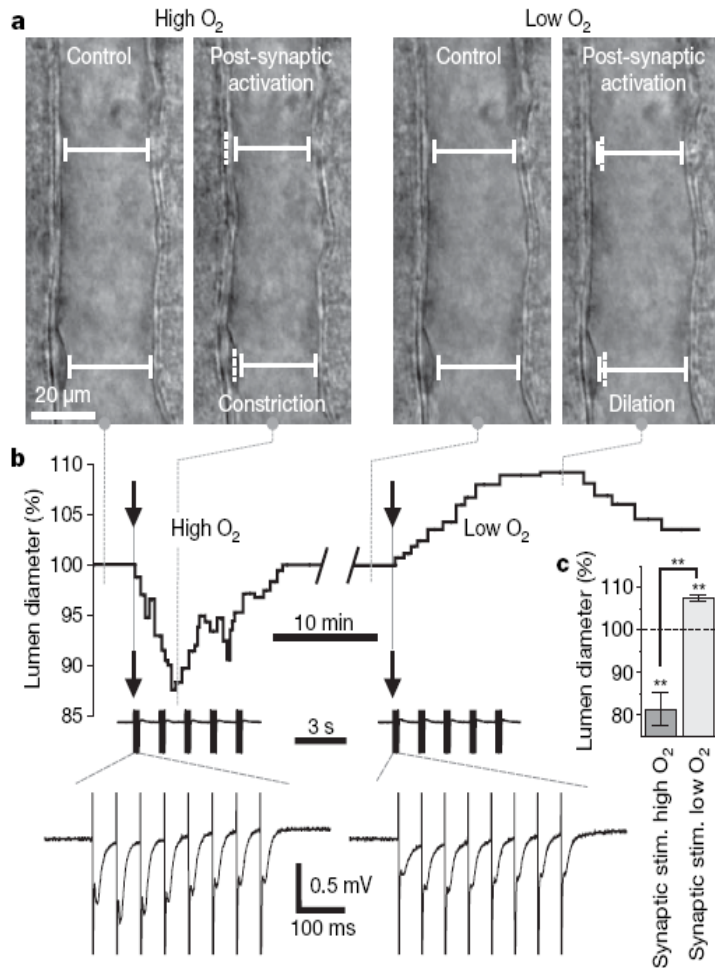

O<sub>2</sub> levels determine whether synaptic activity leads to arteriolar vasodilation or vasoconstriction (via prostaglandines)

**Figure 1 | Lowering  $p_{O_2}$  converts vasoconstriction to vasodilation.**

**a**, Arteriole before and after synaptic activation in high O<sub>2</sub> (left) and low O<sub>2</sub> (right). Dashed vertical lines indicate the previous position of the vessel wall. **b**, Top: vessel lumen diameter changes over time in the same vessel shown in **a**. Arrows indicate time of afferent stimulation. Bottom: two expanded timescales show the stimulation protocol (350-ms, 20-Hz train repeated 5 times at 0.75 Hz) and the first train of the field excitatory postsynaptic potentials evoked, verifying synaptic activity. **c**, Summary data ( $n = 6$ ). In all figures, experimental values are the mean  $\pm$  s.e.m. Double asterisk,  $P < 0.01$ .